

S6300

SERVICE MANUAL

REVISION 0

The Canon logo is displayed in a bold, black, sans-serif font. The letter 'C' is significantly larger than the other letters, and the 'o' contains a vertical bar through its center.

AUG. 2001

082001 XX 0.00-0

S6300

SERVICE MANUAL

Canon

Application

This manual has been issued by Canon Inc. for qualified persons to learn technical theory, installation, maintenance, and repair of products. This manual covers all localities where the products are sold. For this reason, there may be information in this manual that does not apply to your locality.

Corrections

This manual could include technical inaccuracies or typographical errors due to improvements or changes in the products. When changes occur in applicable products or in the content of this manual, Canon will release technical information as the need arises. In the event of major changes in the contents of this manual over a long or short period, Canon will issue a new edition of this manual.

The following paragraph does not apply to any countries where such provisions are inconsistent with local law.

Trademarks

The product names and company names described in this manual are the registered trademarks of the individual companies.

Copyright

This manual is copyrighted with all rights reserved. Under the copyright laws, this manual may not be copied, reproduced or translated into another language, in whole or in part, without the written consent of Canon Inc., except in the case of internal business use.

Copyright © 2001 by Canon Inc.

CANON INC.

i Printer Technical Support Dept. 11

16-1, Shimonoge 3-chome, Takatsu-ku, Kawasaki, Kanagawa 213-8512, Japan

This manual has been produced on an Apple Power Macintosh 7300/180 personal computer and OKI MICROLINE 803 PSIIV laser beam printer; printing films were printed on Agfa SelectSet Avantra 25. All page layouts, logos, and parts-list data were saved with Canon Optical Disc Subsystem mo-5001S™ and Optical Disc Cartridge mo-502M™, and Interface Kit mo-IF2™ for Macintosh. All graphics were produced with MACROMEDIA FREEHAND™ 7.0J. All documents and all page layouts were created with QuarkXpress™ 3.3 Japanese version.

I. ABOUT THIS MANUAL

This manual consists of four parts containing information for servicing the product.

Part 1: Product Specifications

Product overview and specifications.

Product
Specifications

Part 2: Troubleshooting

A guide to troubleshooting the product and identifying parts needing replacement. Troubleshooting solutions are listed according to the error indications displayed by the status indicator and by problem descriptions.

Troubleshooting

Part 3: Technical Reference

Block diagrams and information on the hardware's new technologies.

Technical
Reference

Part 4: Appendix

Pin configurations.

Appendix



REF.

Disassembly and reassembly procedures are not fully covered in this manual. Refer to the illustrations in the separate Parts Catalog as well.

II. TABLE OF CONTENTS

	<i>Part 1: PRODUCT SPECIFICATIONS</i>
1 - 1	1. PRODUCT OVERVIEW
1 - 1	1.1 Product Overview
1 - 2	2. SPECIFICATIONS
1 - 2	2.1 Printer Specifications
1 - 2	2.1.1 Printer specifications
1 - 3	2.1.2 Printer service life
1 - 3	2.1.3 BJ cartridge service life
1 - 4	2.2 Paper Specifications
1 - 4	2.2.1 Paper sizes and weights
1 - 4	2.2.2 Paper types and settings
1 - 5	2.2.3 Printing area
1 - 6	2.3 BJ Cartridge Specifications
1 - 6	2.4 Printer and Scanner Drivers
1 - 7	3. PACKING CONFIGURATION
1 - 8	4. PARTS CODE LIST
	 <i>Part 2: TROUBLESHOOTING</i>
2 - 1	1. PRINTER OPERATION
2 - 1	1.1 Printer Operation Procedure
2 - 1	1.2 Status Indicator
2 - 2	1.3 Operating the Printer
2 - 2	1.3.1 Cleaning operation
2 - 2	1.3.2 Printing the nozzle check pattern
2 - 4	1.3.3 Roller cleaning operation
2 - 5	2. SERVICING
2 - 5	2.1 Before Troubleshooting
2 - 6	2.2 Detectable Problems from System Start to Exit
2 - 9	2.3 Troubleshooting Problems
2 -10	2.4 Troubleshooting Error Indications
2 -13	3. DISASSEMBLY AND REASSEMBLY
2 -13	3.1 Cautions for Disassembly and Reassembly
2 -13	3.1.1 Cautions for ink stains (Ink path/ink mist)
2 -13	3.1.2 Damage by static electricity
2 -13	3.1.3 Deformation of spur tips
2 -14	3.2 Exploded View
2 -15	3.3 Disassembly and Reassembly
2 -15	3.3.1 Carriage lock release
2 -16	3.3.2 Removing and installing tap screws
2 -16	3.3.3 Installing and removing the carriage encoder film
2 -17	3.3.4 Handling encoder film
2 -17	3.3.5 Removing and installing the control board
2 -17	3.3.6 Removal of red screws prohibited
2 -18	3.3.7 Installing the logic board cover
2 -18	3.3.8 Handling the purge unit
2 -19	3.4 Adjustments and Settings After Disassembly and Reassembly
2 -19	3.4.1 Adjustments
2 -20	3.4.2 Applying grease
2 -21	3.4.3 Print head position adjustment
2 -22	3.4.4 Print head seam stripe adjustment

Page	
2 -23	3.4.5 Setting the EEPROM
2 -24	4. OPERATION CHECK AFTER DISASSEMBLY AND REASSEMBLY
2 -24	4.1 Check Procedure
2 -25	5. TRANSPORTING THE PRINTER
2 -25	5.1 Procedure
2 -26	6. PARTS REPLACEMENT, PERIODIC INSPECTIONS, & TOOLS
2 -26	6.1 Parts Replacement
2 -26	6.2 Periodic Inspections
2 -26	6.3 Tool List
2 -27	7. SERVICE-RELATED FEATURES
2 -27	7.1 Service Mode Operations
2 -28	7.2 Test Printout
2 -29	7.3 Printing the EEPROM Information
2 -30	7.4 Resetting the EEPROM
2 -30	7.5 Setting the Printer Settings in the EEPROM

Part 3: TECHNICAL REFERENCE

3 - 1	1. PRINTER CONTROL SECTION
3 - 1	1.1 Printing Data and Control Signal Flow
3 - 2	1.2 Print Drive Method
3 - 3	1.2.1 Print drive control
3 - 4	1.2.2 Print driving method
3 - 5	1.3 Control During Printing
3 - 5	1.3.1 2-dot Pair + Bi-directional printing
3 - 5	1.3.2 Seam stripe control
3 - 5	1.3.3 Rest between scans (Border detection control)
3 - 6	1.3.4 Smear control and rest between pages
3 - 6	1.3.5 Automatic power ON/OFF
3 - 6	1.3.6 Print head protection from overheating
3 - 6	1.3.7 Power motor control
3 - 7	1.4 Detection Functions
3 - 7	1.4.1 Detection by sensors
3 - 7	1.4.2 Paper-end sensor
3 - 8	1.4.3 Ink sensor (Same as for BJ F600)
3 - 8	1.4.4 Cover sensor
3 - 8	1.4.5 Pump sensor
3 - 9	1.4.6 Internal temperature sensor
3 - 9	1.4.7 Head temperature sensor
3 - 9	1.4.8 ASF sensor
3 - 9	1.4.9 Carriage encoder/paper feed encoder
3 - 9	1.5 Other Sensing Features
3 - 9	1.5.1 Waste-ink detection
3 - 9	1.5.2 Print head detection
3 -10	2. ELECTRICAL DRIVE SECTION
3 -10	2.1 Block Diagram
3 -11	2.2 Electrical Section
3 -12	3. PRINTER'S MECHANICAL PARTS
3 -12	3.1 Overview of the Printer's Mechanical Parts
3 -12	3.1.1 Carriage
3 -12	3.1.2 Purge section
3 -13	3.1.3 Paper feed section
3 -14	3.2 Purge Section
3 -14	3.2.1 Purge section functions

Page	
3 -15	3.2.2 Purge section components
3 -17	3.3 Paper Feed Section
3 -17	3.3.1 Paper feed components
3 -18	3.3.2 Friction separation system
3 -18	3.3.3 Paper transport section
3 -18	3.3.4 Paper discharge section
3 -19	4. LOGIC BOARD COMPONENTS
3 -22	5. OPERATION WITH A COMPUTER
3 -22	5.1 Printing Operation with the Basic Settings Sheet
3 -22	5.2 Using the Utility Sheet
3 -23	6. INK SUCTION AMOUNT IN THE CLEANING MODE
3 -24	7. TECHNICAL REFERENCE
3 -24	7.1 Printing Mode List
3 -25	8. PRINT HEAD

Part 4: APPENDIX

4 - 1	1. CONNECTOR LOCATIONS AND PIN CONFIGURATIONS
4 - 5	1.1 Carriage Board
4 - 7	1.2 Print Head
4 - 8	2. CIRCUIT DIAGRAM

III. ILLUSTRATION INDEX

Page	
	<i>Part 1: PRODUCT SPECIFICATIONS</i>
1 - 1	Figure 1 - 1 Printer Exterior
1 - 3	Figure 1 - 2 1500 Characters Pattern
1 - 3	Figure 1 - 3 JIS SCID No. 5
1 - 5	Figure 1 - 4 Printable Area
1 - 7	Figure 1 - 5 Packing Configuration
	<i>Part 2: TROUBLESHOOTING</i>
2 - 1	Figure 2 - 1 Operation Panel
2 - 3	Figure 2 - 2 Nozzle Check Pattern Printout
2 -14	Figure 2 - 3 Exploded View
2 -15	Figure 2 - 4 Carriage Lock Release
2 -16	Figure 2 - 5 Encoder Film
2 -17	Figure 2 - 6 Do not Remove the Red Screws
2 -18	Figure 2 - 7 Installing the Logic Board Cover
2 -18	Figure 2 - 8 Handling the Purge Unit
2 -20	Figure 2 - 9 Applying Grease
2 -21	Figure 2 -10 Printing Position Adjustment Pattern
2 -22	Figure 2 -11 Seam Stripe Adjustment Pattern
2 -28	Figure 2 -12 Service/Factory Test Printout (Sample)
2 -29	Figure 2 -13 EEPROM Information Printout (Sample)
	<i>Part 3: TECHNICAL REFERENCE</i>
3 - 1	Figure 3 - 1 Printing Signal Flow
3 - 2	Figure 3 - 2 Serial Data
3 - 3	Figure 3 - 3 Print Driving
3 - 4	Figure 3 - 4 Printing Driving Method
3 - 7	Figure 3 - 5 Location of Sensors
3 - 8	Figure 3 - 6 Ink Sensor
3 -10	Figure 3 - 7 Block Diagram
3 -12	Figure 3 - 8 Printer's Mechanical Parts
3 -15	Figure 3 - 9 Purge Section Components
3 -16	Figure 3 -10 Pump Operation
3 -17	Figure 3 -11 Paper Feeding
3 -19	Figure 3 -12 Control Board
3 -22	Figure 3 -13 Basic Settings Sheet (Sample)
3 -25	Figure 3 -14 Nozzle Array
	<i>Part 4: APPENDIX</i>
4 - 1	Figure 4 - 1 Control Board
4 - 5	Figure 4 - 2 Carriage Board
4 - 7	Figure 4 - 3 BJ Cartridge

IV. TABLE INDEX

Page	<i>Part 1: PRODUCT SPECIFICATIONS</i>
1 - 9	Table 1- 1 PARTS CODE
	<i>Part 2: TROUBLESHOOTING</i>
2 -10	Table 2- 1 ERROR INDICATIONS
	<i>Part 3: TECHNICAL REFERENCE</i>
3 -24	Table 3 - 1 PRINTING MODE LIST



Part 1

PRODUCT SPECIFICATIONS

Page	
1 - 1	1. PRODUCT OVERVIEW
1 - 1	1.1 Product Overview
1 - 2	2. SPECIFICATIONS
1 - 2	2.1 Printer Specifications
1 - 4	2.2 Paper Specifications
1 - 6	2.3 BJ Cartridge Specifications
1 - 6	2.4 Printer and Scanner Drivers
1 - 7	3. PACKING CONFIGURATION
1 - 8	4. PARTS CODE LIST

I. PRODUCT OVERVIEW

1.1 Product Overview

“High-Performance Personal and Business Use Color Printer”

While emphasizing out-of-box performance, the S6300 offers default setting high-speed and high-quality printing on plain paper.

With the same engine as the S600, the printer takes full advantage of the S600's features, and supports up to A3+ sized paper to function as a high-performance business-use printer.

Differences from the S600 are as follows:

(1) Supported size of paper

Up to A3+ (S600: A4)

(2) Print speed (measured with A4-sized paper)

Monochrome printing, text (HS): 17 ppm (New monochrome pattern*1)

Color printing, DTP (HS): 12 ppm (New color pattern*1)

Color printing (for reference): 2.5 ppm (A4 full address pattern*2)

(3) Paper eject support function to prevent smearing

*1: Standard pattern to measure print speed, in use since 1998.

*2: Dot-by-dot printing performed at 1,200 x 1,200 dpi on A4-sized paper
"Standard Color Printer for Personal Use"

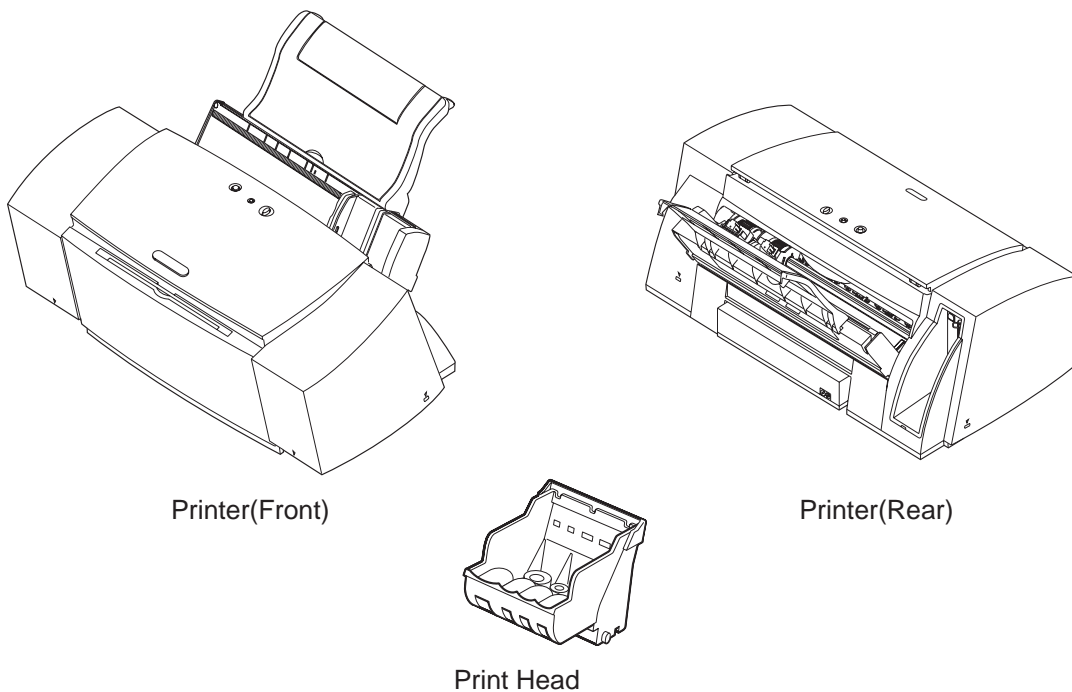

Figure 1-1 Printer Exterior

2. SPECIFICATIONS

2.1 Printer Specifications

2.1.1 Printer specifications

Type	Desktop serial printer			
Paper Feed System	Automatic feed only (No manual feed)			
Resolution	2400 × 1200 dpi (Max. resolution)			
Throughput	Bk: 17 ppm Color: 12 ppm			
Printing Direction (Plain/Special paper)	HS mode (600 dpi × 600 dpi...): Single-pass bi-directional HQ mode (600 dpi × 600 dpi/1200 dpi × 1200 dpi): Single-pass unidirectional/double- or triple-pass bi-directional Fine1 mode (1200 dpi × 1200 dpi/As above): 1.2-pass unidirectional/4- or 6-pass bi-directional Fine2 mode (As above/As above): 4-pass bidirectional/4-pass unidirectional or bi-directional Fine3 mode (.../2400 dpi × 1200 dpi): 4-pass unidirectional or 6-pass bi-directional			
Max. Printing Width	322.2mm (12.7inch) wide			
Interface	IEEE 1284-standard, 8-bit parallel, USB (No HUB function)			
ASF Capacity	Plain paper: Max. 10 mm (Approx. 100 sheets with 75 g/m ² or approx. 110 sheets with 64 g/m ²)			
Sensors	Front cover-open sensor, Print Head-loaded sensor, No-ink sensor, Printing position sensor, Paper sensor (paper out detector), Waste-ink capacity sensor, Internal temperature sensor, Pick-up roller sensor, Paper-feed roller position sensor, Carriage position sensor, Paper interval sensor			
Operating Noise (at HQ)	39 dB (A) Sound pressure level conforms to ISO 9296.			
Ambient Conditions	During operation: Temperature 5°C-35°C (41°F-95°F) Humidity 10%-90% RH (No condensation) During non-operation: Temperature 0°C-40°C (32°F-95°F) Humidity 5%-90% RH (No condensation)			
Power Source	Power voltage/frequency	Power consumption	During standby	When Off
	100-127 VAC 50/60 Hz	Max. approx. 33 W	Approx. 3 W	Approx. 1 W
	220-240 VAC 50/60 Hz	Max. approx. 33 W	Approx. 3 W	Approx. 1 W
External Dimensions	Approx. 573 mm (W) × 335 mm (D) × 194 mm (H)			
Weight	Approx. 7 kg (excluding Print Head)			
Certification (Printer & adapter)	Radio wave interference: VCCI, FCC, IC, C-Tick, Taiwan/Korea EMC, CCIB (EMC)/CCEE Electrical safety: Electrical appliance regulation, UL, Cul, CE Mark, TUV, FIMKO, SASO, AS, PSB, Korean Electric Commerce, CB/CCIB/CCEE Environmental: Energy Star, Blue Angel			
Serial No. Location	Carriage ribbon cable holder (visible when the access cover is open)			

2.1.2 Printer service life

Whichever comes first:

- (1) A total of 30,000 sheets printed with 1,500 standard characters in black ink.
- (2) A total of 10,000 sheets printed with 7.5% duty per color.
- (3) Five years of use.

2.1.3 BJ cartridge service life

(1) Service life

For monochrome printing (1500-character standard text pattern printing): 30,000 pages

For color printing (7.5% duty pattern printing per color): 10,000 pages

(2) Ink tank service life (printable pages per tank)

Monochrome (black): 695 pages (1500 characters pattern*1/Printing quality: Standard)

Color (Cyan): 460 pages (JIS SCID No. 5*2/Printing quality: Standard)

(Magenta): 395 pages (As above)

(Yellow): 300 pages (As above)

*1 Printing duty: Equivalent to 2.22% pattern

*2 Printing duty: Equivalent to 3.68% (cyan) pattern
 Equivalent to 5.12% (magenta) pattern
 Equivalent to 6.10% (yellow) pattern



Figure 1-2 1500 Characters Pattern



Figure 1-3 JIS SCID No. 5

2.2 Paper Specifications

2.2.1 Paper sizes and weights

(1) Paper sizes

See the table below.

(2) Weight

For automatic feeding, the paper's weight should be 64-105 g/m².

2.2.2 Paper types and settings

Type		Size	Sheet Feeder Capacity	Paper Spacing Lever Position
Plain paper	64-105 g/m ²	A3+/A3/b4/A4+/A4 B5/A5/LGL/LTR	Less than 10 mm	Left (Narrow)
High-quality paper	HR-101	A3/b4/A4+/A4/B5/A5 LGL/LTR A3+	Less than 80 sheets Less than 20 sheets	Left (Narrow)
Photo glossy paper	GP-301	A4+/A4/LTR A3+/B4/LGL	10 sheets 1 sheet	Left (Narrow)
Photo paper	PR-101	A4/LTR	1 sheet	Left (Narrow)
Glossy film	HG-201	A4/LTR	1 sheet	Left (Narrow)
Transparency film	CF-102	A4/LTR	Less than 30 sheets	Left (Narrow)
Banner	BP-101	A4/LTR	1 sheet	Right (Wide)
T-shirt transfer	TR-201	A4/LTR	1 sheet	Right (Wide)
Mouse pad	MK-101	---	1 sheet	Left (Narrow)
Glossy postcard	KH-201	148 mm × 100 mm	Less than 20	Left (Narrow)
Photo glossy card	FM-101	118.6 mm × 213.9 mm	Less than 20	Left (Narrow)
Japan Post Office postcard	---	148 mm × 100 mm	Less than 40	Left (Narrow)
Japan Post Office postcard for ink jet printing	---	148 mm × 100 mm	Less than 40	Left (Narrow)
Pro photo postcard	PH-101	148 mm × 100 mm	Less than 20	Left (Narrow)
Envelope	COM#10	241 mm × 106 mm	Less than 10	Right (Wide)
	DL-size	220 mm × 110 mm	Less than 10	Right (Wide)
	No. 4	235 mm × 105 mm	Less than 10	Right (Wide)
	No. 6	190 mm × 98 mm	Less than 10	Right (Wide)



If the paper spacing lever is not properly set, problems with paper feeding or printing may occur.

2.2.3 Printing area

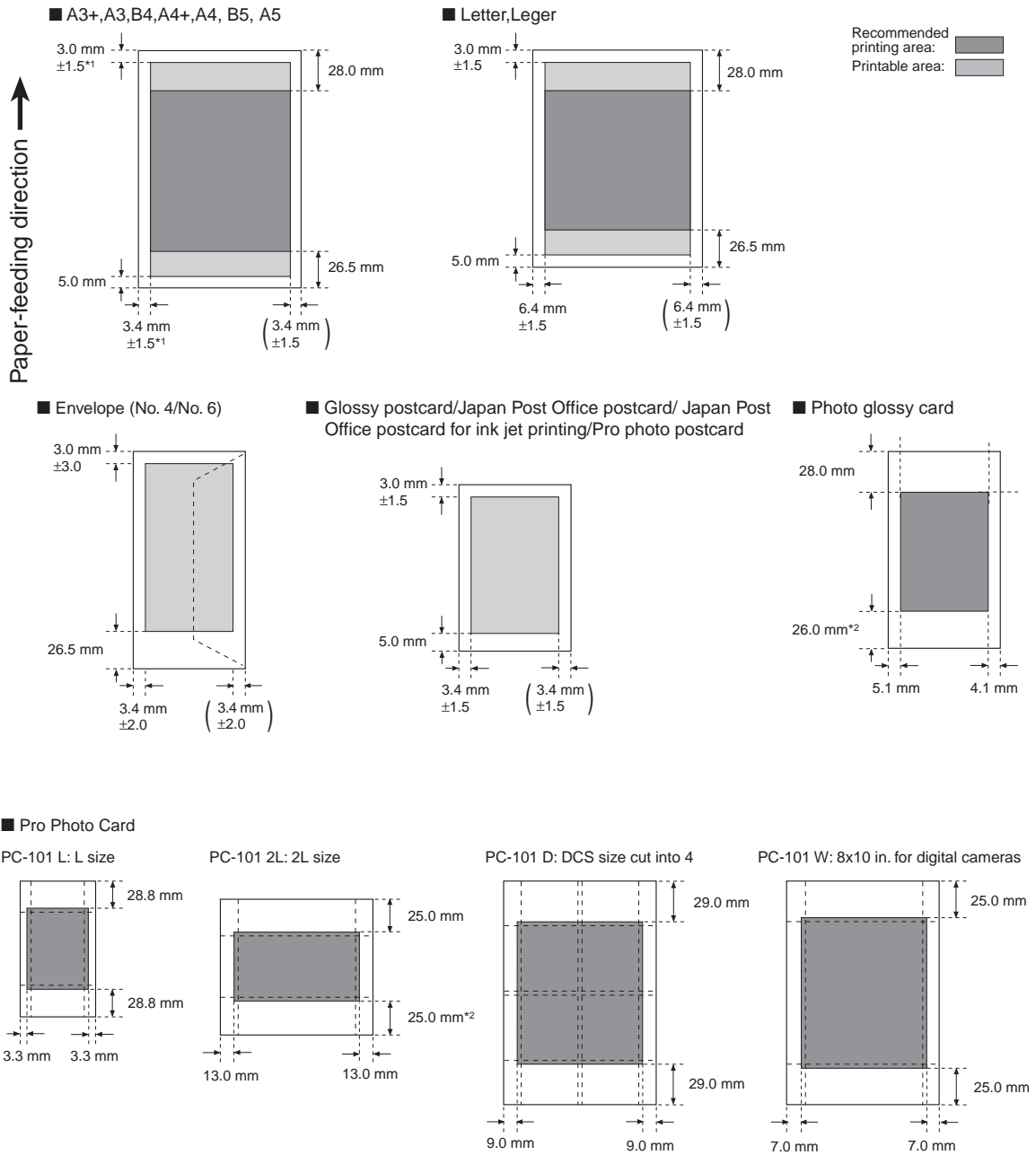

Product Specifications

*1 For recycled paper, it will be 3.0mm ±3 or 3.4mm ±2.
 *2 If the bottom margin goes beyond the plain paper's printable area, the software application's specifications will apply.
 The region inside the dotted lines is the printable area where print quality can be guaranteed.
 Note: The right margins in parentheses indicate that the dimension depends on the paper size.

Figure 1-4 Printable Area

2.3 BJ Cartridge Specifications

	Print Head
Configuration	Detachable ink tanks for each color and BK/CI (C, M, Y) integrated head
Print Head	BK: 320 nozzles, 2-column vertical array CI: 256 nozzles/color, 2-column vertical array/color
Ink Colors*	Pigment BK, dyes C, M, Y
Ink Tank	BCI-3eBK, BCI-3eC, BCI-3eM, BCI-3eY
Weight (Net value)	BK: 32 g CI (C, M, Y): 11 g

2.4 Printer and Scanner Drivers

The user interface of the drivers has been greatly improved. See [page 3-22](#) for details.

1 Windows drivers

Win95/98/ME BJ raster driver (V. 7.10)

Win9NT4.0 BJ raster driver (V. 4.40)

Win2000 BJ raster driver (V. 1.40)

2 Macintosh driver

Mac BJ printer driver (V. 3.75)

3 Scanner driver

None.

3. PACKING CONFIGURATION

After opening the box, make sure all the items below are included.

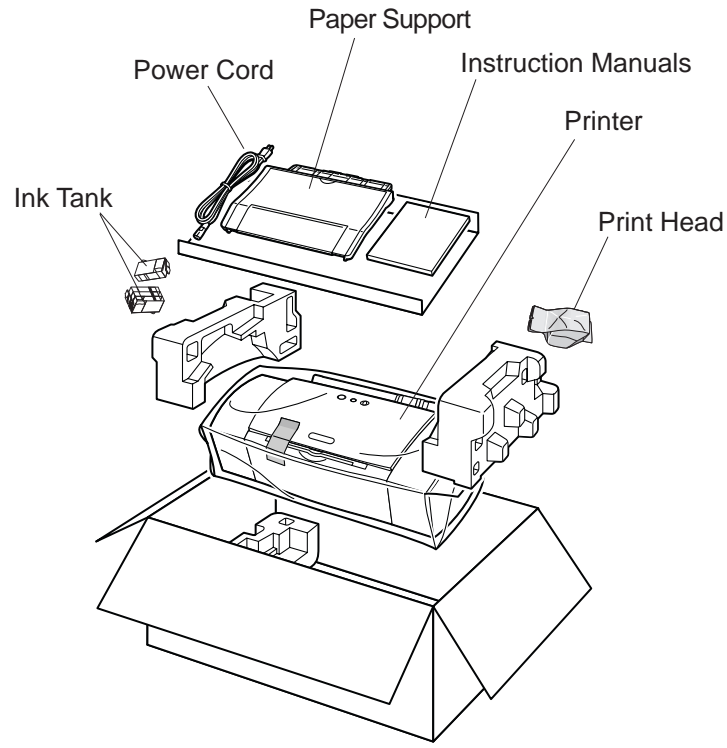

Product Specifications

Figure 1-5 Packing Configuration



There is no storage box for storing the Print Head.

4. PARTS CODE LIST

A list of printer parts, consumables, and optional equipment are listed below.
The printer's BJ cartridge (print head) will be supplied only as a spare part for servicing.

Table 1-1 PARTS CODE

Item		Designation	Parts Code
Printer	---	S6300	Q30-3480 (CCSEK) Q30-3482 (HK/TW)
		BJ S6300	Q30-3481
Print Head* ¹	---	---	QY6-0034
Ink tank	Black	BCI-3eBK	F47-3131
	Cyan	BCI-3eC	F47-3141
	Magenta	BCI-3eM	F47-3151
	Yellow	BCI-3eY	F47-3161

*1 Supplied only as a spare part for servicing. It will not be supplied as a consumable or optional part.

This page intentionally left blank



Part 2

TROUBLESHOOTING

Page	
2 - 1	1. PRINTER OPERATION
2 - 1	1.1 Printer Operation Procedure
2 - 1	1.2 Status Indicator
2 - 2	1.3 Operating the Printer
2 - 5	2. SERVICING
2 - 5	2.1 Before Troubleshooting
2 - 6	2.2 Detectable Problems from System Start to Exit
2 - 9	2.3 Troubleshooting Problems
2 -10	2.4 Troubleshooting Error Indications
2 -13	3. DISASSEMBLY AND REASSEMBLY
2 -13	3.1 Cautions for Disassembly and Reassembly
2 -14	3.2 Exploded View
2 -15	3.3 Disassembly and Reassembly
2 -19	3.4 Adjustments and Settings After Disassembly and Reassembly
2 -24	4. OPERATION CHECK AFTER DISASSEMBLY AND REASSEMBLY
2 -24	4.1 Check Procedure
2 -25	5. TRANSPORTING THE PRINTER
2 -25	5.1 Procedure
2 -26	6. PARTS REPLACEMENT, PERIODIC INSPECTIONS, & TOOLS
2 -26	6.1 Parts Replacement
2 -26	6.2 Periodic Inspections
2 -26	6.3 Tool List
2 -27	7. SERVICE-RELATED FEATURES
2 -27	7.1 Service Mode Operations
2 -28	7.2 Test Printout
2 -29	7.3 Printing the EEPROM Information
2 -30	7.4 Resetting the EEPROM
2 -30	7.5 Setting the Printer Settings in the EEPROM

1. PRINTER OPERATION

The printer's operation procedures are explained below. You can operate the printer either by itself or with a computer. Both methods are explained below.

1.1 Printer Operation Procedure

The printer's operation panel has a *POWER* button and a *RESUME* button to cancel printing operation or to cancel an error. With a computer, you can use the printer driver to adjust the print head's position and to change various settings. For details on using the printer driver with the computer, see page 3-22.

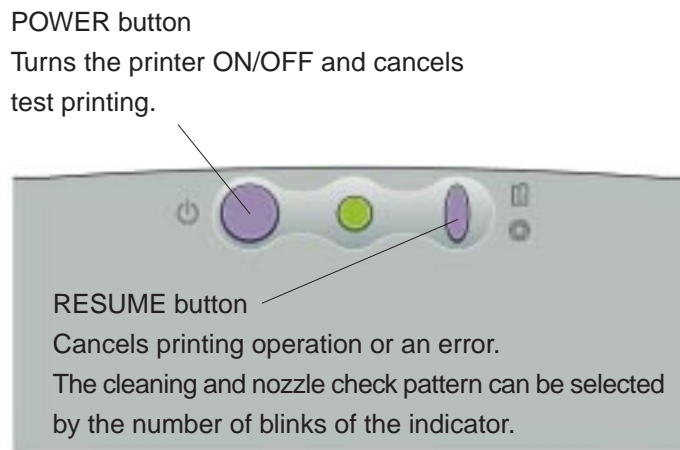

Figure 2-1 Operation Panel

1.2 Status Indicator

When you operate the printer by itself, you can find out the printer's operation status with the indicator. When an error occurs, the nature of the error can be determined by the number of times the indicator blinks.

Normal Operation

Indicator Display	Operation Status
Green light	Power ON
Blinks green (Long/short)	Power ON in progress, power OFF in progress, resume operation in progress, cleaning in progress, test printing in progress, front cover open, printing in progress
Light off	Power OFF

Error

Indicator Display	Operation Status
Blinks orange (Long/short)	The number of blinks differs depending on the error. See page 2-10 for details.
Green/orange (Toggle blinking)	The blinking method differs depending on the error. See page 2-11 for details.

1.3 Operating the Printer

The printer has an offline operation mode that works when the printer is not connected to a computer and the power is on.

To conduct the operations below, with the power turned on, hold down the *RESUME* button until the green indicator blinks for the specified number of times.

Operation	Indicator Blink Count	Remarks
Cleaning operation	Once	---
Nozzle check pattern printing	Twice	Load a sheet of B5 or larger paper.
Roller cleaning operation	3 times	Load no paper or load A4 paper.
---	4 times	Execute no operations.

1.3.1 Cleaning operation

To start the cleaning operation, turn on the printer and hold down the *RESUME* button until the green indicator blinks once. Then let go of the button. Cleaning will then start. The black and color ink nozzles will be cleaned simultaneously by suction. This is the same as using the printer driver to clean all of the ink nozzles.

1.3.2 Printing the nozzle check pattern

With the printer turned on, hold down the *RESUME* button until the green indicator blinks twice. The printer will then start printing the nozzle check pattern. If any printing flaws show up in this test printout, clean the BJ cartridge.



Printing the nozzle check pattern requires B5 or larger paper. If the paper's width is narrower than the nozzle check pattern, the printer will print on the bare platen, dirtying the platen with ink.



To stop printing of the test pattern midway, press the *POWER* button. Printing will stop and the paper will be ejected. The printer will remain on.



If the problem persists even after cleaning the BJ cartridge three times, Perform Deep Cleaning of from the driver. If that still does not resolve the problem, replace the BJ cartridge.

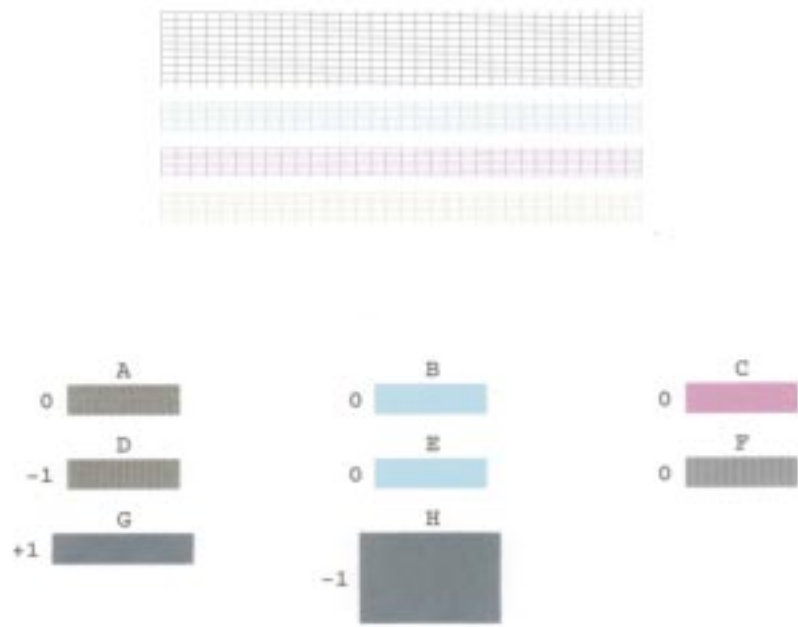

Troubleshooting

Figure 2-2 Nozzle Check Pattern Printout

1.3.3 Roller cleaning operation

This is to remove the paper dust adhering to the auto sheet feeder's rollers. With the printer turned on, hold down the *RESUME* button until the green indicator blinks once. The cleaning of the rollers will then start.

There are two cleaning methods:

(1) Rotating the rollers without paper

Execute roller cleaning without placing any paper on the auto sheet feeder.

(The rollers will rotate ten times.)

Do this three times.

(2) Passing plain paper through

Place a sheet of plain paper on the auto sheet feeder and execute roller cleaning.

Do this three times.



Do not execute the cleaning operation more times than necessary. Excessive cleaning will generate rubber dust which can affect the printer's operation.

2. SERVICING

2.1 Before Troubleshooting

Before troubleshooting, check the following and see if any of the applicable problems can be fixed.

Problem	Probable Cause	Solution
The printer does not operate at all.	The power outlet is not supplying the required voltage.	Connect the AC cord to a power outlet which supplies the required voltage.
	The power cord is not properly connected to the printer or power outlet.	Check that the power cord is connected properly.
	An internal plug is disconnected.	Disconnect and reconnect the plug.
Paper feeding does not work.	The recommended paper is not being used.	Use the recommended paper.
	There is foreign matter in the paper feed section (sheet feeder, pinch roller, LF roller, platen, spur).	Remove the foreign matter.
No printing.	The Print Head needs cleaning.	Clean the Print Head.
	The ink cartridge is empty.	Replace the ink cartridge.
	The Print Head has not been used for a prolonged period.	Clean the cartridge. If the problem still persists, replace the cartridge.
Stripes appear in the printout.	The print head position has not been adjusted.	Execute print head position adjustment.
		See page 2-23.

2.2 Detectable Problems from System Start to Exit

Errors unresolvable by the user can be checked before system startup is completed.

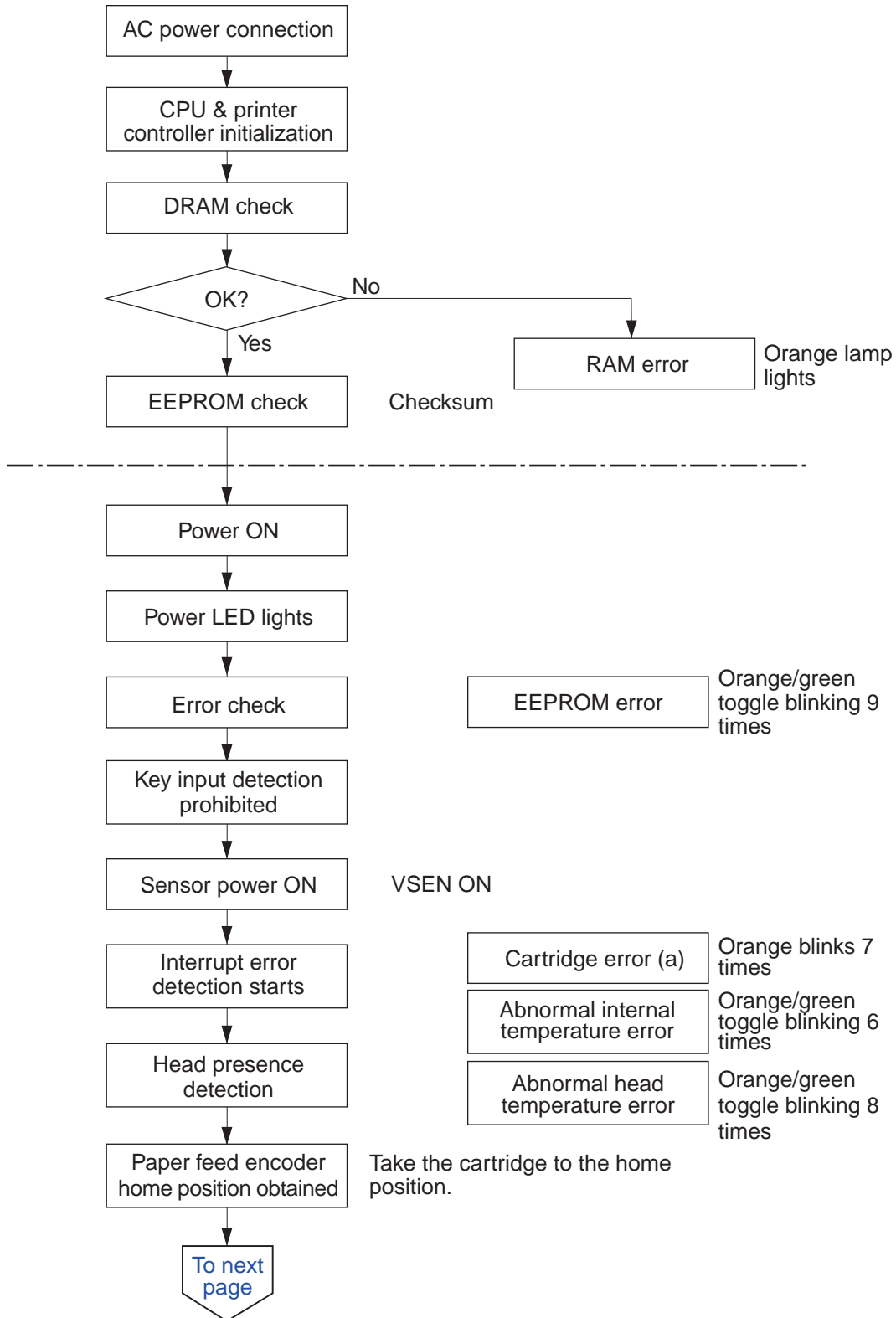

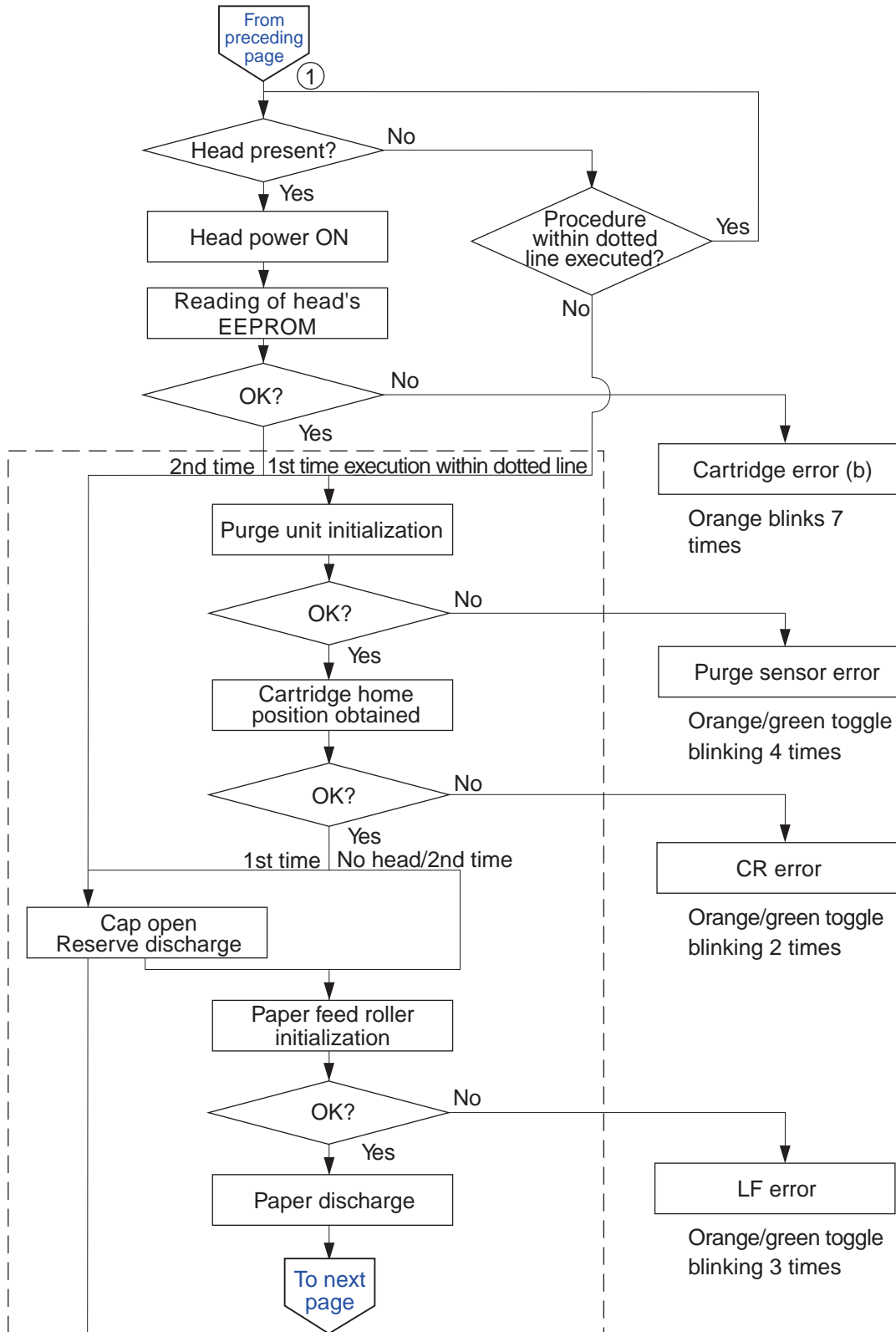

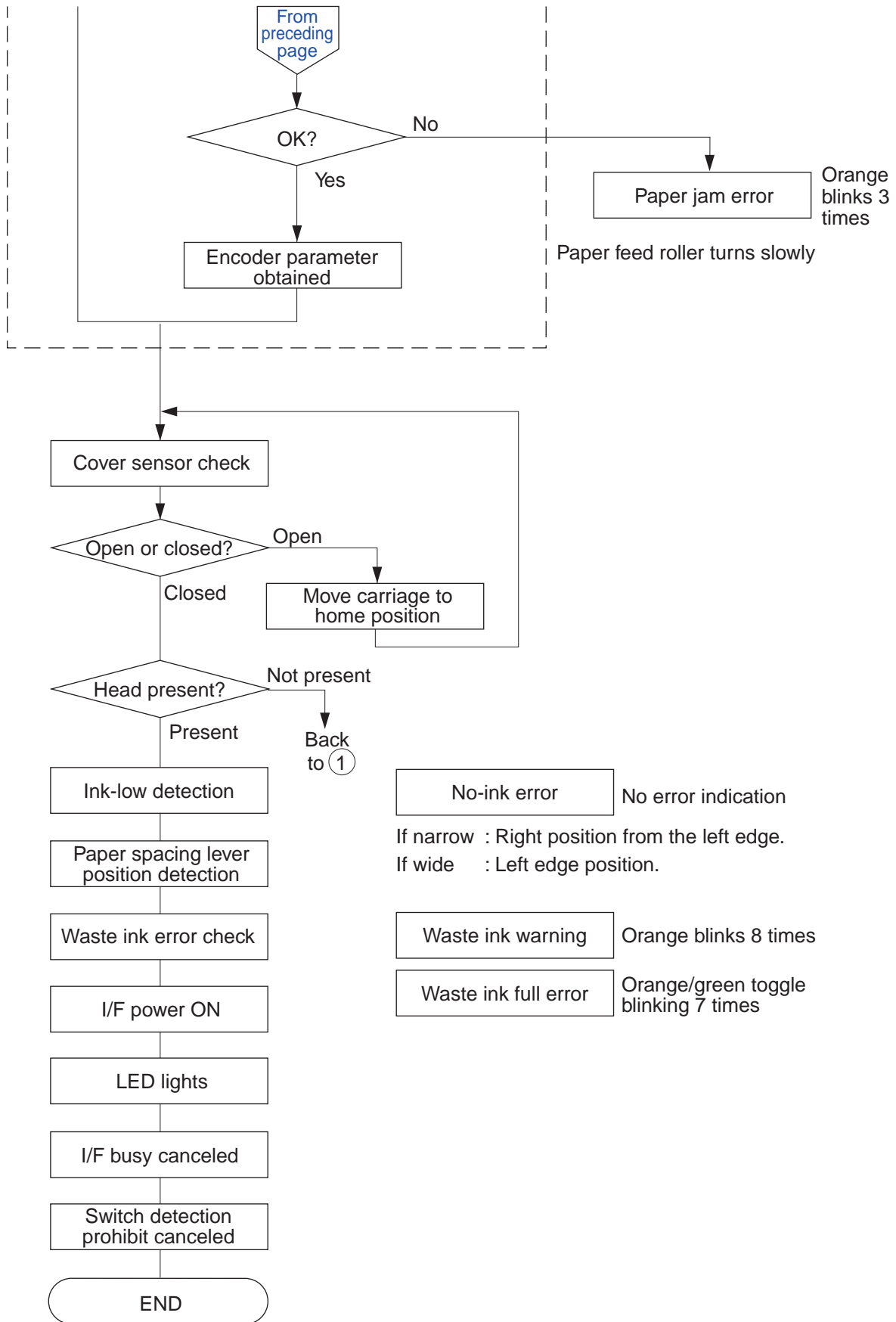

2.3 Troubleshooting Problems

	Problem	Probable Cause / Check Items	Solution
Faulty Operation	Power does not turn on. After power ON, it immediately turns off.	1. AC adapter, 2. Logic board	1. Replace faulty parts.
	The print head is not recognized. It does not return to the home position.	1. Print Head, 2. Print Head contacts, 3. Carriage flex cable	1. Remove and reinstall the Print Head. 2. Replace faulty parts.
	Abnormal noise.	1. Dislodged parts, 2. Dislodged pinch roller.	1. Remove foreign matter, 2. Reinstall dislodged parts.
	Printing stops midway.	1. Control board	1. Replace faulty parts.
Faulty Paper Feed	Multiple sheets are fed at a time.	1. ASF (Return tab, faulty pressure roller operation)	1. Replace faulty parts.
	Paper is not fed.	1. Foreign matter, 2. PE sensor arm	1. Remove foreign matter, 2. Replace faulty parts
	The paper is slanted.	1. Paper guide, 2. Foreign matter adhering to paper feed rollers	1. Readjust the paper guide to the correct position, 2. Remove foreign matter.
Faulty Printout	No printing. No color.	1. Print Head, 2. Ink tank, 3. Purge unit	1. Replace faulty parts.
	Scrape marks or white stripes appear even after cleaning. Lines not in the printing data appear.	1. Print Head, 2. Ink tank, 3. Purge unit, 4. Print Head faulty contacts, 5. Carriage flex cable	1. Remove and reinstall Print Head and check the contacts, 2. Replace faulty parts.
	The paper is dirtied.	1. Ink mist from the paper transport section in the printer.	1. Pass through several sheets of paper. 2. Use a cloth to clean the paper transport section.
	Spur marks appear.	1. Deformed spur tips.	1. Replace faulty parts.
	Broken vertical lines appear.	1. Paper spacing lever position not properly set. 2. Improper amount of grease applied on guide shaft.	1. Set the paper spacing lever to the proper position. 2. Adjust the printing position. 3. Apply the correct amount of grease on the guide shaft.
	Lines are missing.	1. Ink tank	1. Replace ink tank.
	Strange color tones.	1. Print Head	1. Replace faulty parts.
	Overlapping printing	1. Platen unit (eject roller)	1. Replace faulty parts.

2.4 Troubleshooting Error Indications

- 1) Error indication when a user-resolvable error occurs
The indicator lights in green, then blinks in orange. This repeats.
Check the number of blinks and proceed to correct the error.
- 2) Error indication when an error not resolvable by the user occurs
The indicator toggles between orange and green (orange/green toggle blinking). This repeats.
Check the number of toggled blinks and proceed to correct the error.

*1: The error code is displayed by the computer. With the iMac and Power Macintosh G3, a "D" or "M" is appended to the beginning of the error code.

*2: The waste-ink warning can be canceled by pressing the *RESUME* button.

*3: Press the *RESUME* button to resume operation.

Table 2-1 ERROR INDICATIONS

<i>Indicator Blink Count</i>	<i>Error Status Code*1</i>	<i>Probable Cause and Faulty Parts</i>
User-Recoverable Errors		
Orange 2 blinks	--- Paper feed error	<Cause> 1. No paper was loaded. 2. During feeding, the paper did not reach the paper-end sensor. 3. During feeding, the paper's bottom edge missed the paper-end sensor. 4. The ASF sensor did not return to its initial position and the paper-end sensor concluded that there was no paper. (ASF motor may be out of sync.) <Suspect Part> Paper feed section, sheet feeder unit, paper-end sensor, control board
Orange 3 blinks	--- Paper jam error	<Cause> 1. The paper-end sensor still detects the presence of paper even after 23 inches of paper ejection operation. 2. The ASF sensor did not return to its initial position and the paper-end sensor concluded that there was no paper. (Out of sync.) 3. During paper feeding abnormal timing caused the paper-end sensor to still detect paper. <Suspect Part> Paper feed section, paper-end sensor, control board
Orange 4 blinks	--- No-ink error*3	<Cause> The respective ink tank has run out of ink (in the tank and sponge). <Suspect Part> Ink tank

Orange 6 blinks	---	BJ cartridge not installed	<Cause> Since there is no Print Head installed, the printing and suction that were required could not be executed. <Suspect Part> Print Head, carriage unit
Orange 7 blinks	---	Cartridge error	<Cause> (a) The print head temperature (output value of the head's internal diode sensor) exceeded the threshold. (b) Print Head EEPROM's checksum <Suspect Part> Print Head
Orange 8 blinks	---	Waste-ink warning*2	<Cause> The total waste ink count recorded in the EEPROM exceeds 95% of the "full" stipulated value. <Suspect Part> Waste ink absorber, control board

User-Unresolvable Errors

Orange/ green 2 toggle blinks	5100	CR error	<Cause> The carriage's encoder signal is abnormal. <Suspect Part> Encoder film, carriage unit, control board, flex cable
Orange/ green 3 toggle blinks	6000	LF error	<Cause> The carriage's encoder signal is abnormal. <Suspect Part> Encoder film, paper feed sensor unit, control board
Orange/ green 4 toggle blinks	5C00	Purge sensor error	<Cause> At the sensor's ON timing, it turns OFF. Or vice versa. <Suspect Part> Purge unit, control board
Orange/ green 6 toggle blinks	5400	Abnormal internal temperature error	<Cause> The temperature sensor (TH401) on the control board is abnormal (disconnected, etc.). <Suspect Part> Control board
Orange/ green 7 toggle blinks	5B00	Waste ink full error	<Cause> The waste ink absorber has reached 100% of the waste ink capacity. <Suspect Part> Waste ink absorber, control board
Orange/ green 8 toggle blinks	5200	Abnormal head temperature error	<Cause> The print head temperature (output of the diode sensor in the head) is close to the threshold. <Suspect Part> Print Head, control board

Orange/ green 9 toggle blinks	6800 EEPROM error	<Cause> An error occurred during the writing to the EEPROM. Checksum error (at soft power ON). <Suspect Part> Control board
Orange/ lights	--- RAM error	<Cause> Error at DRAM check (at hard power ON). <Suspect Part> Control board
Internal Error		
No indications	--- Ink sensor error	<Cause> No-ink indication is given while there is still ink. External noise (light) has affected the ink sensor. <Suspect Part> Control board, ink sensor, ink tank

3. DISASSEMBLY AND REASSEMBLY

3.1 Cautions for Disassembly and Reassembly

3.1.1 Cautions for ink stains (Ink path/ink mist)

During servicing, be careful not to touch the ink path and get ink stains on the printer, work table, and your hands and clothing.

The ink path includes the Print Head's ink tank supply inlet, the Print Head's ink filter, the ink nozzles, head cap, wiper, and waste-ink absorber.

Also, a printer that has seen long-time use or heavy-duty use may have ink mist soiling the platen, inside the front cover, and purge section.

3.1.2 Damage by static electricity

The rubbing of clothing can cause a build up of static electricity on the human body. Static electricity can destroy electrical components or alter the electrical characteristics of components.

Be extra careful when handling the control board.

3.1.3 Deformation of spur tips

Be careful not to deform the spur tips.

The spur tips contact the paper after the printing. Since the spur tips' contact area is small, any ink adhering to the spur will be a minuscule amount that can be wiped off by the spur cleaner. It therefore will not dirty the paper. However, if the spur's tips are bent out of shape, the contact area with the paper will be larger, and any ink adhering to the spur will be a larger amount that the spur cleaner might not be able to wipe off completely. The spur will then stain the paper with a dotted line.

3.2 Exploded View

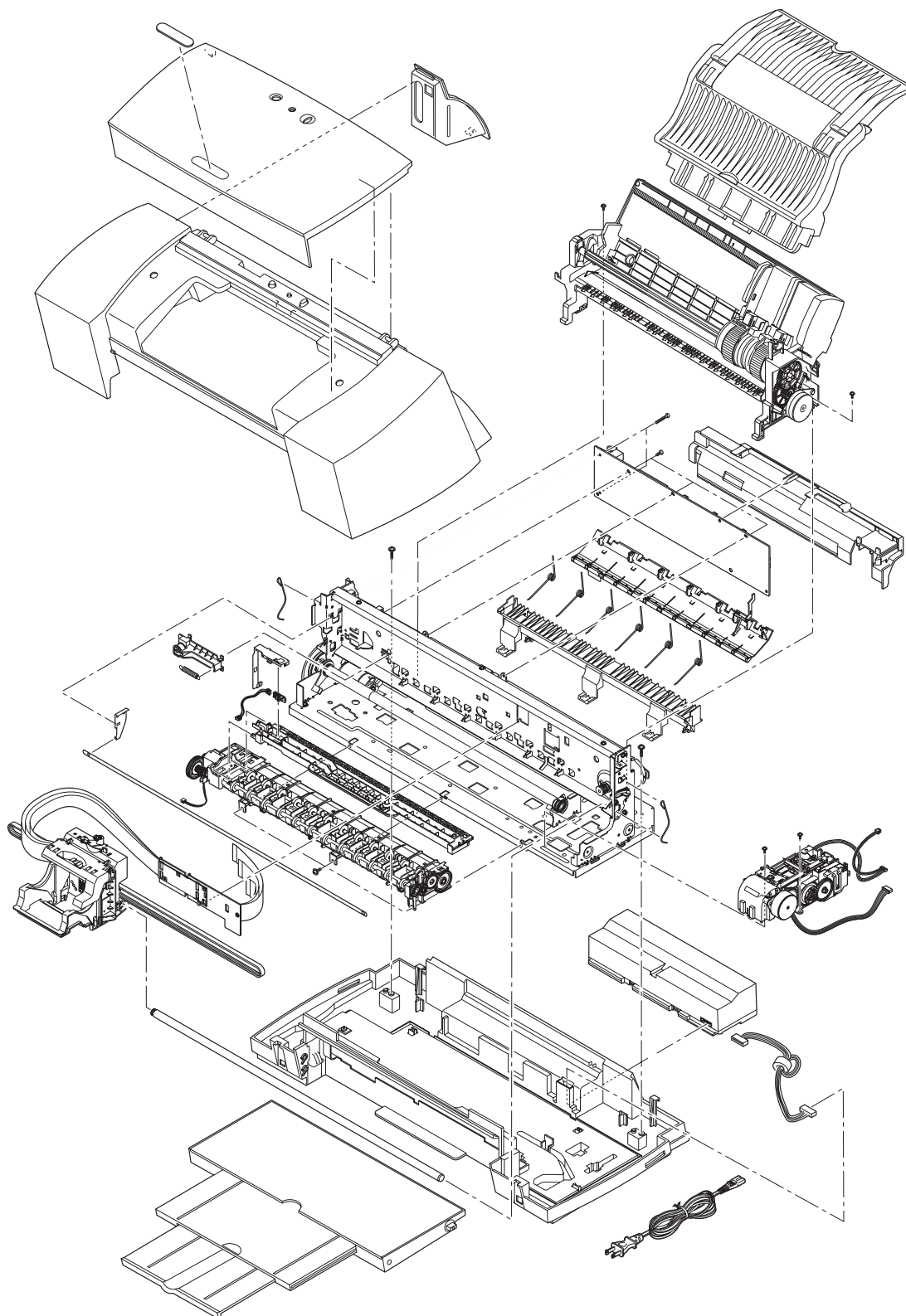

Figure 2-3 Exploded View

3.3 Disassembly and Reassembly

Supplemental information and cautions for disassembling and reassembling the printer are stated below.

As for the disassembly procedure, refer to the Parts Catalog. The illustrations in the Parts Catalog are numbered according to the order of disassembly.

3.3.1 Carriage lock release

Normally, when a cartridge is installed on the carriage and the power is turned off, the printer moves the carriage to the capping position to lock it.

When the power is turned on, the carriage lock is normally released. However, if the printer does not operate properly, you can release the carriage lock manually in one of two ways:

- a) On the back of the printer, push down the purge unit's locking pin.
- b) On the front of the printer, rotate the gear as shown by the arrow in the illustration below so that the locking pin goes down.

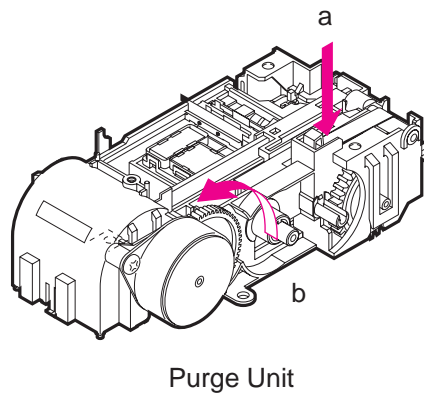

Figure 2-4 Carriage Lock Release

3.3.2 Removing and installing tap screws

The printer uses tap screws to fasten the printer unit and base. The removed tap screws will have residue from the mold in which the internal thread was made. Since the residue may crush the screw threads, clean off the residue from the tap screws before re-installing or use new tap screws.

3.3.3 Installing and removing the carriage encoder film

The carriage encoder film is fixed in place and held taut by the torsion spring. When you install or remove the carriage encoder film, you have to stretch the torsion spring. Be careful not to pull the torsion spring too much in the direction of the arrow. Otherwise, you will not be able to properly install the carriage encoder film the next time.

Therefore, when installing or removing the carriage encoder film, be very careful not to pull the torsion spring too much.

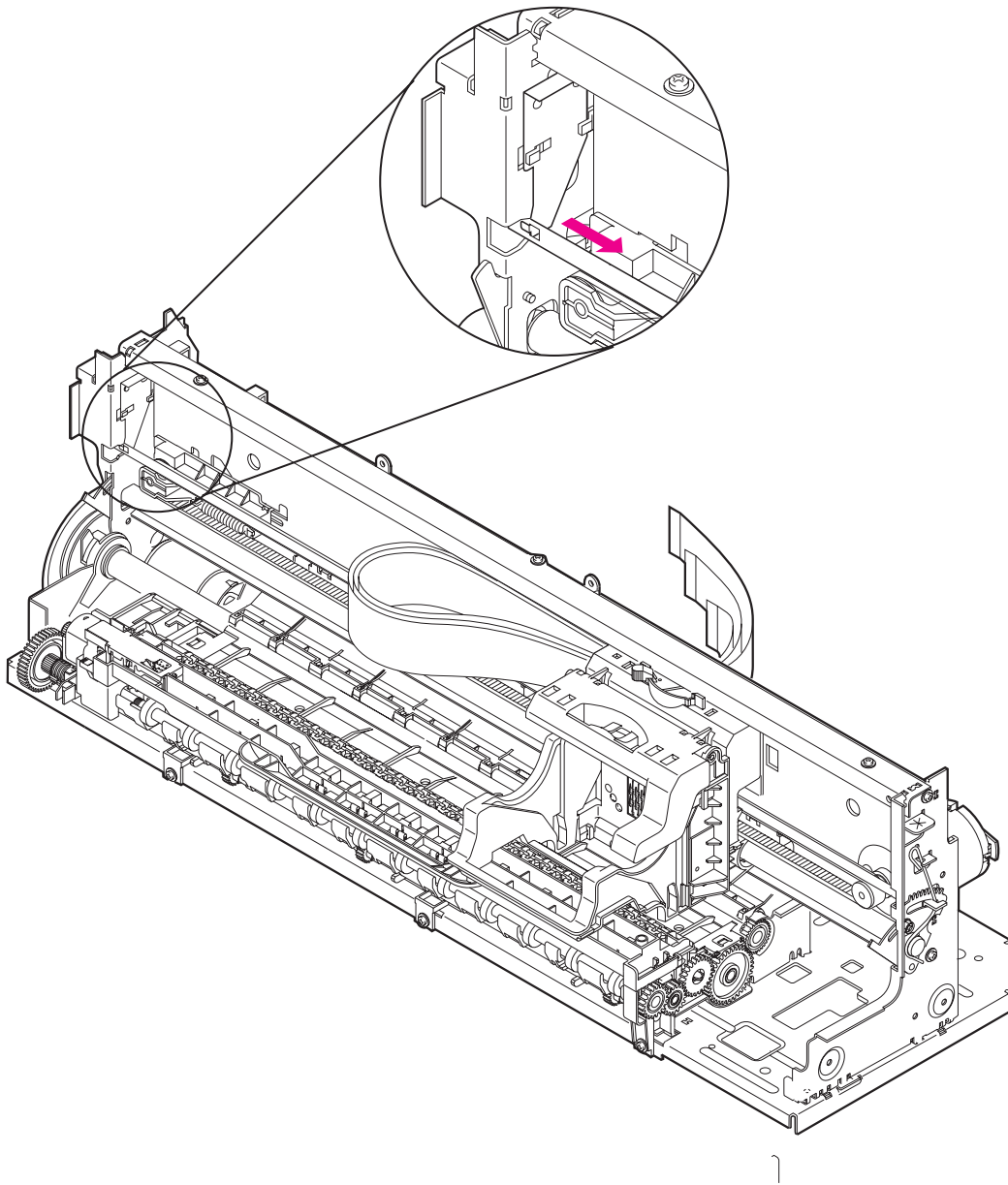

Figure 2-5 Encoder Film

3.3.4 Handling encoder film

- (1) Be careful not to get any grease on the encoder film (carriage encoder film and paper feed encoder film).
If grease gets on the encoder film, the film's slits will not be read correctly, resulting in error. If grease gets on the film, use alcohol to wipe it off completely.
- (2) Do not fold or scratch the encoder film.
If the film is folded and a white line is created or if a slit is scratched, replace the encoder film.

3.3.5 Removing and installing the control board

Remove or install the control board with caution to prevent damage caused by short circuiting.

When the printer is turned on and later turned off, the capacitor on the control board will still contain a charge for a while. In this condition, shorting the components on the control board will damage the components.

Therefore as a preventive measure, after disconnecting the AC power, wait for 90 sec.

3.3.6 Removal of red screws prohibited

Since adjustment of the following red screws is very difficult in the field, they must not be loosened or removed.

- (a) The two paper spacing red screws (one on the right and left).
- (b) The two screws securing the paper feed motor.

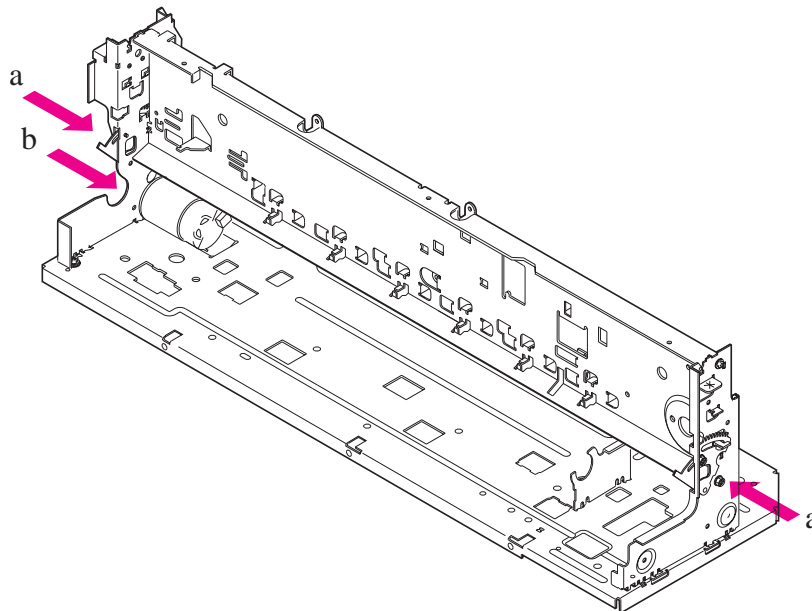

Figure 2-6 Do not Remove the Red Screws

3.3.7 Installing the logic board cover

If the logic board cover is installed incorrectly, the logic board and paper feed rollers will be obstructed and the ASF motor may go out of sync.

Note that prong A is prone to engage incorrectly. Make sure that it fits in correctly.

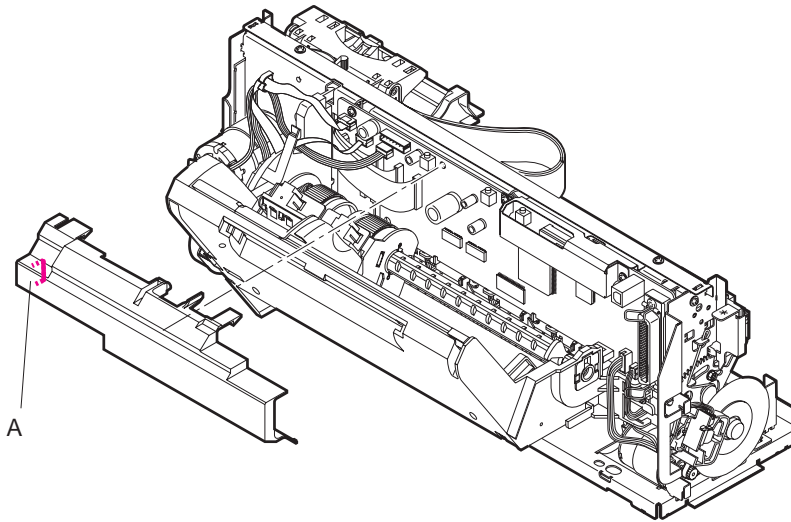

Figure 2-7 Installing the Logic Board Cover

3.3.8 Handling the purge unit

Note the following with regard to the purge unit:

(1) Grease soiling the blade

Due to the blade's height, the carriage guide shaft may touch it when the shaft is removed or installed. Grease may soil the blade as a result.

You must not allow any grease or oily substance to adhere to the blade.

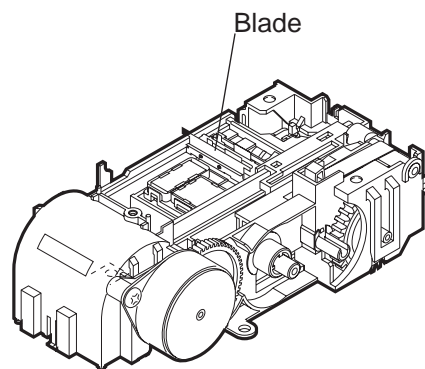

Figure 2-8 Handling the Purge Unit

3.4 Adjustments and Settings After Disassembly and Reassembly

3.4.1 Adjustments

(1) User Level

Timing	Adjustment	Time Required	Tools Required
After BJ cartridge replacement	Print head printing position adjustment	10 min.	2 sheets of A4-size paper

(2) Serviceman Level

Timing	Adjustment	Time Required	Tools Required
After control board replacement or waste-ink absorber replacement	EEPROM setting	2 min.	None
After replacement/disassembly of carriage unit parts	Print head printing position adjustment (including seam adjustment)	10 min.	2 sheets of A4-size paper
Insufficient grease	Apply sufficient grease. See page 2-20	---	Grease PG-641, FLOIL KG107A, brush

3.4.2 Applying grease

After disassembly and reassembly, apply the necessary grease on the places shown below.

Use a flat brush to spread a thin coat of grease.



When applying grease, be careful not to get any grease on the wiper and cap.

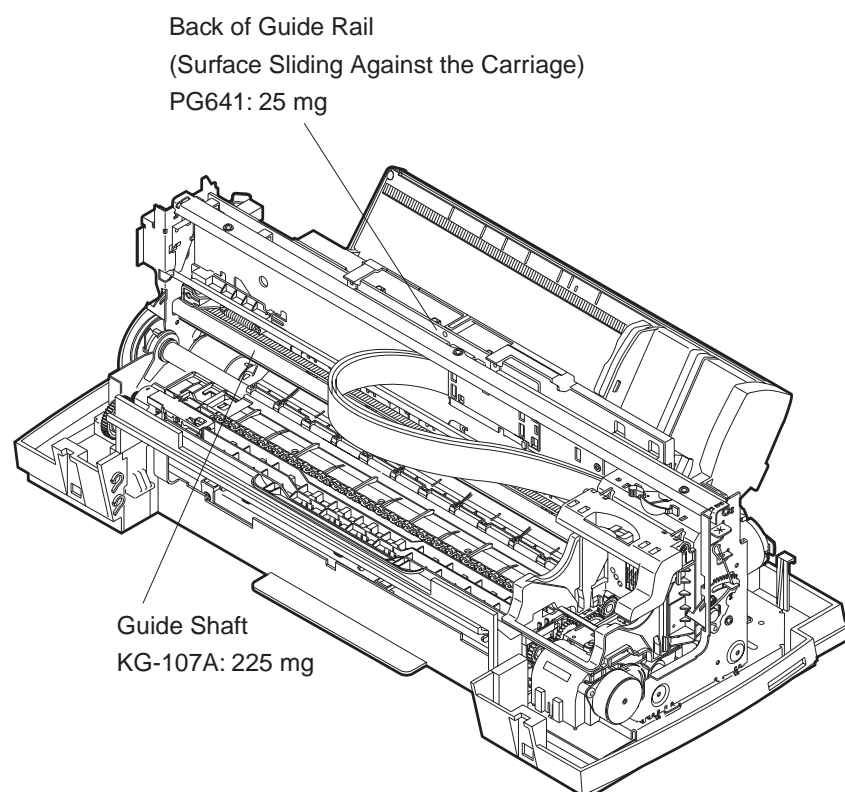

Figure 2-9 Applying Grease

3.4.3 Print head position adjustment

The print head has two nozzle arrays for each color. Therefore, it requires the ink landing position adjustments described in (1) and (2) below in addition to the usual bi-directional adjustment described in (3).

- (1) Landing position adjustment between two same-color arrays
 - Black-Black array (A)
 - Cyan-Cyan array (B)
 - Magenta-Magenta array (C)
- (2) Landing position adjustment between two different-color arrays
 - Black-cyan/Magenta/Yellow (F)
- (3) Bi-directional landing spot adjustment (Same as with previous models)
 - Black bi-directional (D)
 - Color bi-directional (E)

If the landing spot position is inaccurate, the pattern printing will show overlapping printing or gaps, resulting in black or white stripes.

Therefore when doing the adjustment, use a pattern that has no stripes.

Load one sheet of A4 paper in the auto sheet feeder, then use the printer driver to execute printing.



Figure 2-10 Printing Position Adjustment Pattern

3.4.4 Print head seam stripe adjustment

The print head seam stripe adjustment is done to determine the amount of thinning of the high-duty image portion (indicated by the arrows) comprising the seam (stripe) created between the vertical bi-directional passes.

After the CMY printing by the first pass, CMY is printed again in the same way during the second pass. In the case of color printing, there are two feed methods for one pass: 64 and 128. Pattern G was made with 64 nozzles, and pattern H was made with 128 nozzles.

When you execute printing with the printer driver, seven patterns with a changing degree of thinning (indicated by the arrows) will be printed vertically.

Select the number of the pattern whose seam stripe is the least noticeable. This sets the optimum degree of thinning.

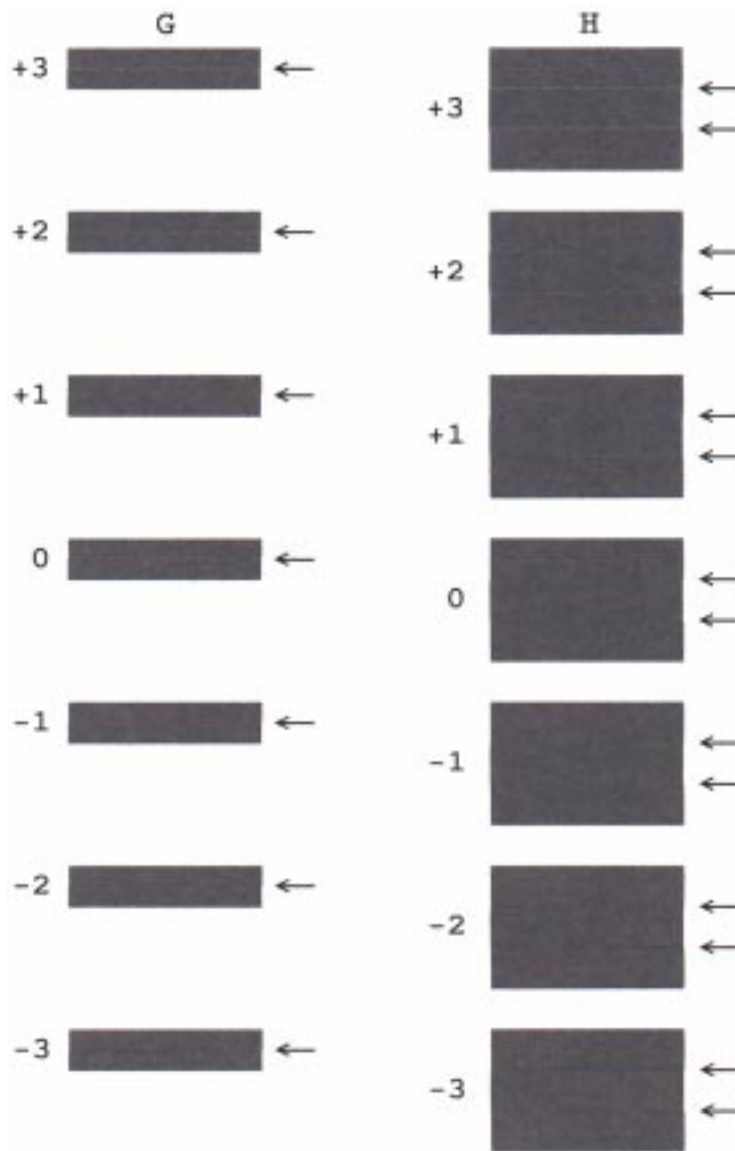

Figure 2-11 Seam Stripe Adjustment Pattern

3.4.5 Setting the EEPROM

After replacing the control board or waste-ink absorber, reset the EEPROM and restore the printer settings. Then do a test printout to check the results.

The procedure is described in *7.1 Service Mode Operations on page 2-27*.

(1) After control board replacement

If the waste-ink absorption amount is over 7 percent (according to a visual check) at the time you replace the control board, also replace the waste-ink absorber. Otherwise, the waste ink amount cannot be counted accurately. Then reset the EEPROM and restore the printer settings.

To check the waste-ink absorption amount, you can either check the service/factory text printout from the old control board or visually check the waste-ink absorber's waste-ink absorption amount.

Also, the new control board (EEPROM) does not have the correct data.

The EEPROM must be reset. Otherwise, the waste-ink full error will not occur even when the waste-ink absorber's capacity is exceeded and ink could leak.

(2) After waste-ink absorber replacement

Clear the EEPROM's waste-ink counter.



Once the data in the EEPROM is reset, a test printout cannot be used to check the old data. Be sure to print the data before resetting.

All the data, except the printer settings and USB serial number, will be reset.

The various settings and waste-ink amount stored in the old EEPROM cannot be written to the new (replacement) EEPROM.



The waste-ink full error is expected to occur only when the printer prints more than the number of sheets specified for its service life. However, how soon this error occurs varies depending on how many times the printer has been turned on/off, the number of times the Print Head has been replaced (front cover open/closing), and the operating environment.

4. OPERATION CHECK AFTER DISASSEMBLY AND REASSEMBLY

4.1 Check Procedure

After disassembly and reassembly, follow the procedure below to check the printer's operation.

1) Check visually for any grease or foreign matter dirtying the internal parts.

Make sure that the encoder film is clean. If there is any grease on the film, wipe it clean with alcohol.

2) Service/factory test printout with the printer alone

Check for the following: Missing print in the nozzle check pattern, off-position horizontal lines in the horizontal line pattern, and white stripes in any irregular printing. If any of these occur, clean the print head and adjust the print head position. Then make another test printout. The procedure is described in [7.1 Service Mode Operations on page 2-27](#).

Timing	Items to Check
After control board replacement	The service/factory test printout must show the correct ROM version and product designation. It must also show the printed sheet count and that the total waste-ink amount has been cleared. The printer driver must be able to print the nozzle check pattern (to confirm that the computer is communicating with the printer).
After absorber replacement	The service/factory test printout must show that the total waste-ink amount has been cleared.



Be sure to visually check the encoder film for any grease, foreign matter, etc. If there is any grease, etc., on the film, the printer may malfunction shortly after the repair is completed.

5. TRANSPORTING THE PRINTER

The procedure for transporting the printer after completing repairs is described below.

5.1 Procedure

- (1) Mount the Print Head on the carriage.
- (2) Turn off the printer so that the carriage locks at the home position.



If the Print Head (print head) is not on the carriage, the ink may dry and harden. So even while transporting the printer, leave the Print Head mounted on the carriage.

Also, if the carriage is not locked at the home position, it will move while the printer is being transported. This may strain the paper feed encoder film.

6. PARTS REPLACEMENT, PERIODIC INSPECTIONS, & TOOLS

6.1 Parts Replacement

Level	Replacement Parts
User	None
Serviceman	None

Level	Consumables
User	Black BJ cartridge ink tank (Black: BCI-3eBK) Color BJ cartridge ink tank (Cyan: BCI-3eC, Magenta: BCI-3eM, Yellow: BCI-3eY)
Serviceman	None

6.2 Periodic Inspections

Level	Periodic Inspections
User	None
Serviceman	None

6.3 Tool List

Ordinary Tools	Remarks
Phillips screwdriver	For the removal and installation of screws.
Blade screwdriver	For the removal of plastic parts.
Needle-nosed pliers	For the removal and installation of springs.
Tweezers	For the disconnection and connection of flexible cables, etc.
Flat brush	For applying grease.
Multi-meter	For troubleshooting.

Special Tools (Part No.)	Remarks
Grease MOLYKOTE PG-641 (CK-0562)	To be applied on the specified parts (see Figure 2-20).
Grease MOLYKOTE KG107A (QY9-0057)	To be applied on the specified parts (see Figure 2-20).

7. SERVICE-RELATED FEATURES

The printer has a service mode for accessing service settings and executing a test printout. You can use the operation panel to switch to the service mode.

7.1 Service Mode Operations

- 1) With the printer turned off, hold down the *RESUME* button and press the *POWER* button (the green indicator lights and the desired service function can be selected).
- 2) While holding down *POWER* button, let go of the *RESUME* button and then press the *RESUME* button twice in succession. Then let go of the *RESUME* button and *POWER* button.
(Each time you press the *RESUME* button, the indicator's color toggles between orange and green.)
- 3) During printer initialization, the green indicator blinks. When the green indicator stops blinking and remains on, press the *RESUME* button the stipulated number of times to execute the desired service function listed below.
(Each time you press the *RESUME* button, the indicator's color toggles between orange and green.)

Press	Indicator	Function
0 times	Lights green	Power off (Even if there is no Print Head mounted, the carriage will return to the home position and lock.)
1 time	Lights orange	Service/factory test printout(Including ink sensor check)
2 times	Lights green	EEPROM information printout
3 times	Lights orange	EEPROM initialization (All the information will be reset to the default, but the printer settings will not be affected.)
4 times	Lights green	Clears the waste-ink counter
5 times	Lights orange	Market area (printer) setting After the power is turned on and a service function is executed, press the <i>RESUME</i> button the stipulated number of times to set the market area setting. (For BJ S6300: Press twice. For S6300: Press once.)
6 times or more	Lights green	Press the <i>POWER</i> button to return to the service function selection mode.

- 4) After selecting the service function, press the *POWER* button. The green indicator lights and the service function will be executed.
(After the respective function is executed, the printer returns to the service function selection mode.)



To cancel printing after it begins, press the *POWER* button. The Power lamp will blink for a while and then stay lit. You can then select another service function.

7.2 Test Printout

The service/factory test printout shows the print head's control ROM version, printer settings, total printed sheet count, total waste-ink absorption amount, and other information.

Paper Size:A3

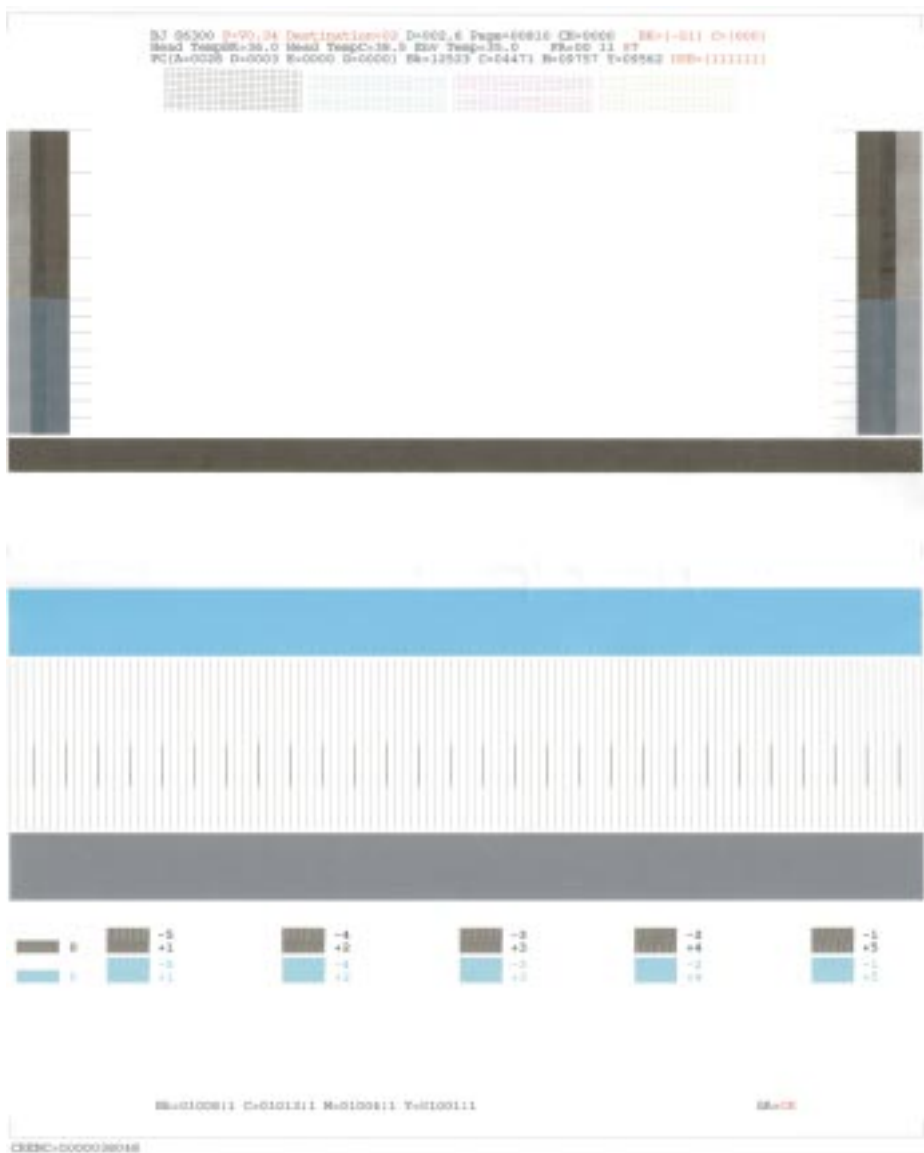

Figure 2-12 Service/Factory Test Printout (Sample)

7.3 Printing the EEPROM Information

This prints the contents of the printer's EEPROM and that of the Print Head. With the resulting printout, you can see the settings and data saved in the printer.

```

S6300      P=V1.00 DI=000.00% Page=00032 CH=00005 Bk=(00) Cl=(00)
Head TempBK=26.5 Head TempC=27.0 Env Temp=27.0 PF(00 00 00)
PC(A=0005 B=0000 C=0000 D=0003) Bk=04214 C=03365 M=01451 Y=01110
WP=0041 IC(BK=0 C=0 M=1 Y=1) Ink tank presence Present: 0 None: 1
USB=(111111) Typing count
SV0=5700 SV1=5C00 SV2=5C00 Service error (Latest, preceding, further previous)
UR(C=000 BK=+02 BK-C=000 Y=000 M=000 G=000 H=+02)
User registration adjustment values (From left: B, A, F, none, C, G, H)

HDEEPROM
V0000 Print head version
SN=24AF-418A Print head serial No.
LN(03 05 01 15 00 00 03) Print head lot No.
DI(BK=+001 CL=+001) Diode sensor (temperature) compensation value (Bk/Cl)
IL(BK=-08 C=-08 M=-08 Y=-08) Ejection level
WLA=-08 WLB=-08
NGBK=000 NGC=000 NGM=000 NGY=000
    
```

Troubleshooting

Figure 2-13 EEPROM Information Printout (Sample)

The error history records the last three (starting with the most recent one) user-unresolvable errors that have occurred. It does not include any ROM/RAM errors.

Error	Error Code
CR error	5100
Abnormal head temperature	5200
Abnormal internal temperature error	5400
Waste-ink full error	5B00
Pump sensor error	5C00
EEPROM Read/Write error	6800

7.4 Resetting the EEPROM

The printer uses the total waste-ink absorption amount recorded by the EEPROM as the basis for determining whether the waste ink is full.

Therefore, after replacing the waste-ink absorber, be sure to reset the total waste-ink absorption amount.

Also, after replacing the control board, be sure to reset the new control board's EEPROM and to also replace the waste-ink absorber.

7.5 Setting the Printer Settings in the EEPROM

The control board used in the printer is also used in other printers. After replacing the control board, the printer settings for the respective printer must be set.

After setting the printer settings, check it with the service/factory test printout.



All the logic boards available as a replacement part contain printer settings for the S6300. Therefore, if the logic board was replaced in Japan, be sure to set the correct printer settings.

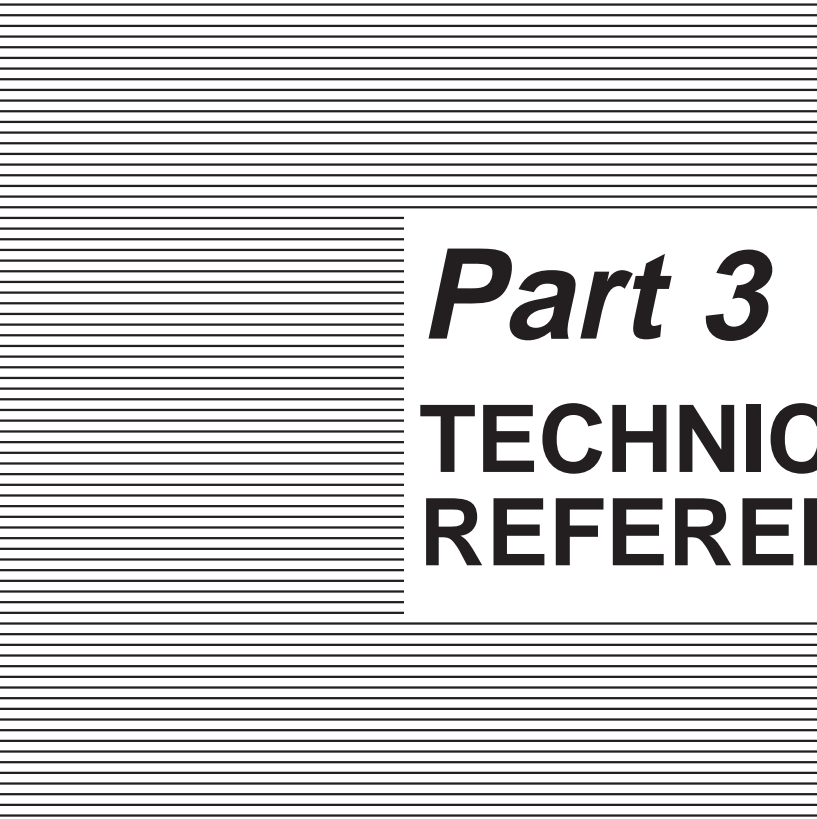

Part 3

TECHNICAL REFERENCE

Page	
3 - 1	1. PRINTER CONTROL SECTION
3 - 1	1.1 Printing Data and Control Signal Flow
3 - 2	1.2 Print Drive Method
3 - 5	1.3 Control During Printing
3 - 7	1.4 Detection Functions
3 - 9	1.5 Other Sensing Features
3 -10	2. ELECTRICAL DRIVE SECTION
3 -10	2.1 Block Diagram
3 -11	2.2 Electrical Section
3 -12	3. PRINTER'S MECHANICAL PARTS
3 -12	3.1 Overview of the Printer's Mechanical Parts
3 -14	3.2 Purge Section
3 -17	3.3 Paper Feed Section
3 -19	4. LOGIC BOARD COMPONENTS
3 -22	5. OPERATION WITH A COMPUTER
3 -22	5.1 Printing Operation with the Basic Settings Sheet
3 -22	5.2 Using the Utility Sheet
3 -23	6. INK SUCTION AMOUNT IN THE CLEANING MODE
3 -24	7. TECHNICAL REFERENCE
3 -24	7.1 Printing Mode List
3 -25	8. PRINT HEAD

1. PRINTER CONTROL SECTION

The printer control section converts the data created and input by the printer driver into printing data and printer operation signals and it also controls the driving of the print head and electrical mechanisms while referring to feedback from various sensors.

1.1 Printing Data and Control Signal Flow

The signal flow starting with the printer receiving the printing data and ending with the execution of printing is explained below.

- a) The printer driver in the computer creates a print file from the image data and compresses the print file. When the printer driver creates the print file, it obtains data concerning the amount of ink to be ejected from the print head. The printer driver refers to this ink ejection amount data. The printer driver can thereby create an optimum print file for the print head.
- b) The print data, including control signal output from the host computer, moves from the interface controlled by the printer controller (on the logic board) and is captured by the printer controller. The printer controller and DRAM are dedicated buses, and the print data is stored in the DRAM's receiving buffer (ring buffer).
- c) The print data stored in the receiving buffer is sent to the MPU. The firmware stored in the control ROM is divided into the control command and print data. The control command is processed in the MPU.
- d) Since the print data is compressed by the printer driver, it is controlled by the printer controller and uncompressed in the DRAM.
- e) When the printer controller receives a printing start request from the MPU, it obtains the print data in the DRAM print buffer.
- f) The printer controller converts the print data into serial data and transfers it as the printing signal to drive the print head. In the print head, the print data is converted from a serial signal into a printing data signal and the printing is executed. (See [Printing Driving Method](#).)
- g) The MPU controls the printer controller, control ROM, and various motor drivers. While monitoring the status of the print head and printer, it also executes overall control of print driving. (See [Sensors and Their Functions and Feedback](#).)

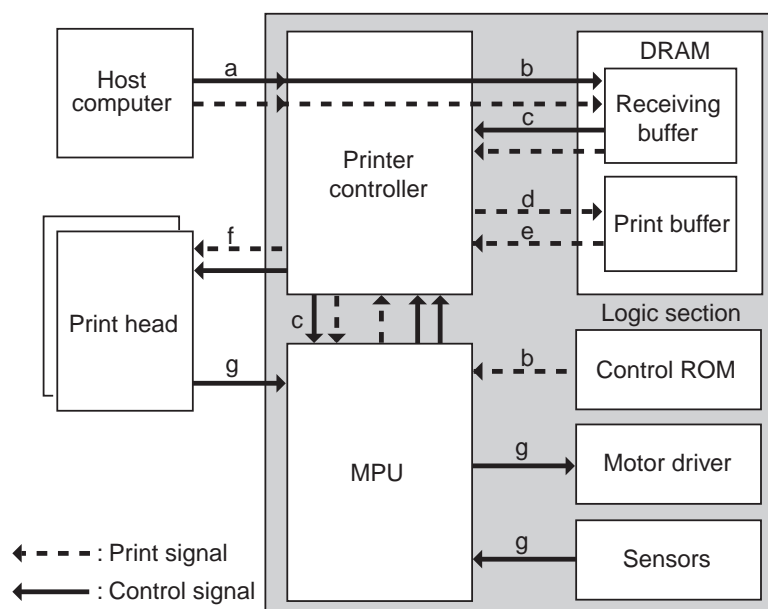

Figure 3-1 Printing Signal Flow

1.2 Print Drive Method

To print, the printer ejects ink from ink nozzles. To this end, 16-bit serial data is transferred once as a latch signal to each nozzle array (total of 8 arrays: black even/odd-number array, cyan, magenta, yellow/even/odd-number array). This operation is repetitive.

The 16-bit serial data includes the following: Data (DATA0 ~ 9) that decides whether or not to heat 10 nozzles, data (BE0 ~ 4) that decides which nozzles to heat, and the dummy heater signal.

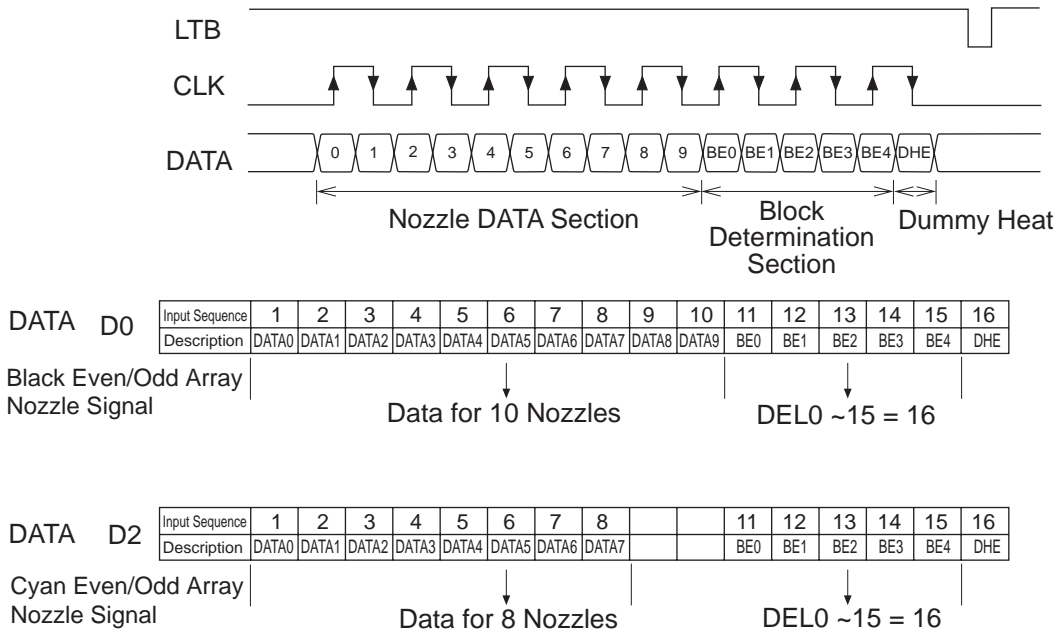
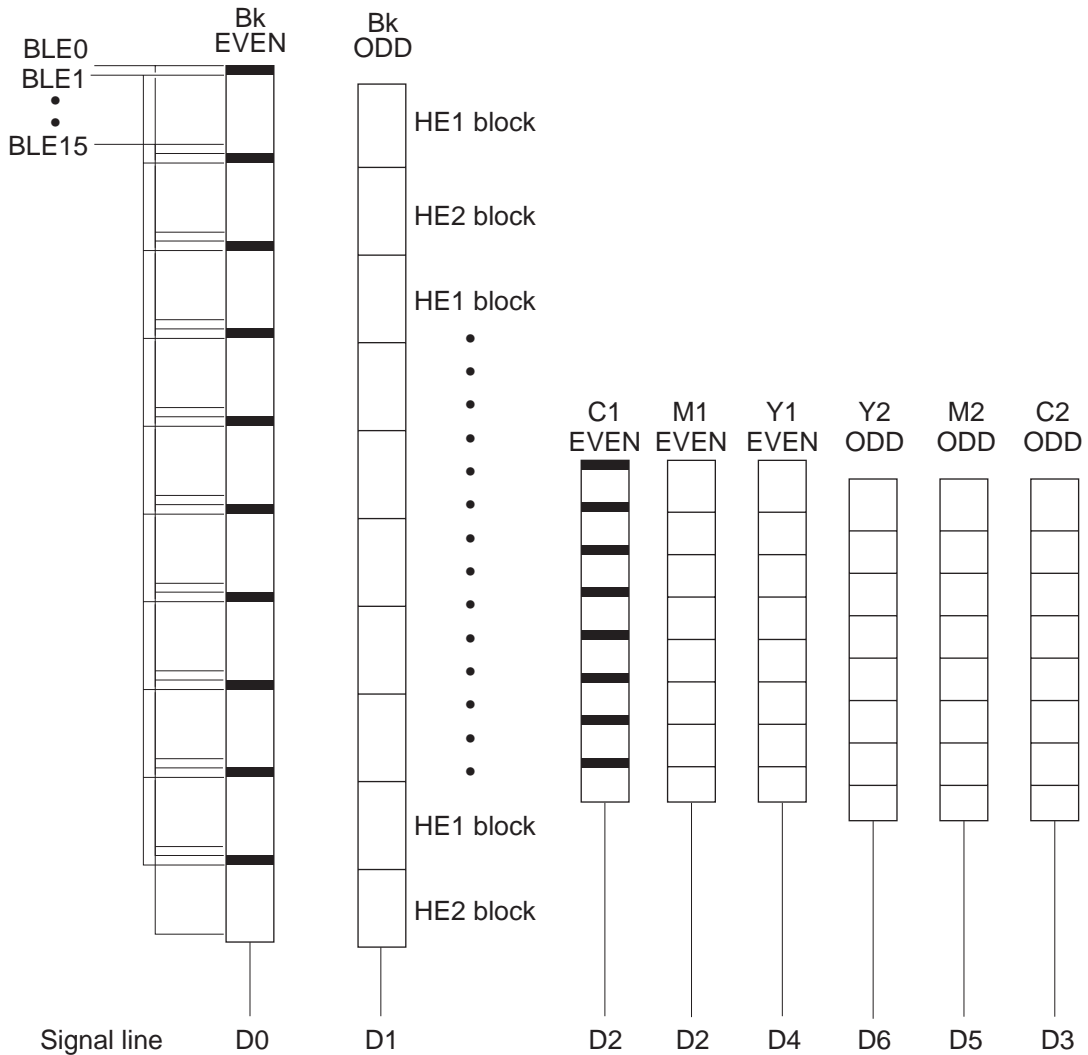

Figure 3-2 Serial Data

1.2.1 Print drive control

Print driving is executed as follows:

- a) The nozzles to be heated are selected in blocks.
 - The nozzles to be heated are selected according to logical blocks of 16 nozzles divided from among the nozzle arrays.
 - In the case of the black nozzles, they are divided into 10 blocks.
 - The top-to-bottom sequence of the ten blocks will be BLE0 to BLE15. For example, in the case of BLE0, it will be as shown in the figure below. Ten nozzles will be selected in this case.
- b) The nozzles to be heated are selected individually.
 - Among the 10 nozzles selected, the nozzles to be heated or not are selected. This is determined by DATA0 to DADA.
- c) Determining whether to heat a nozzle or not.
 - The final decision to heat a nozzle or not is decided with the heat enable signal (HE1/HE2). Only the nozzles in the heat block selected by the heat enable signal are heated.



Product Specifications

Figure 3-3 Print Driving

1.2.2 Print driving method

The printer's drive system enables a maximum of 600 × 600 dpi for black and 2400 × 2400 dpi for color. The vertical resolution applies to two nozzle arrays for each color. In the case of black, the two nozzle arrays have 300 dpi. Since their relative position to each other has been shifted by 600 dpi, both nozzle arrays together attain 600 dpi resolution. This enables 600 dpi resolution with single-pass printing. To enable a horizontal resolution of 2400 dpi, 3-dot printing is made possible in 600 dpi intervals. There are a total of eight patterns to enable or disable printing between the 600 dpi dots.

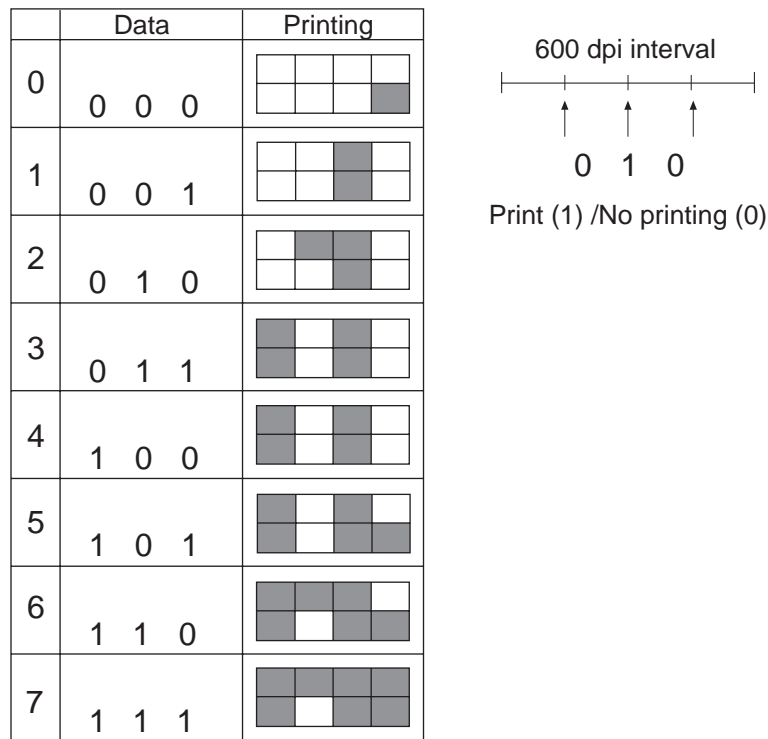

Figure 3-4 Printing Driving Method

Since it is impossible to heat the nozzles successively in the horizontal direction at 2400 dpi intervals, the heating is broken into four passes. Thus, 2400 dpi printing requires four or more passes to be driven. However, the places that will be printed during a pass are determined by a random mask pattern. Therefore, it is not fixed.

1.3 Control During Printing

The printer can produce high-quality printing with no smearing or irregular density with the cartridge, selected media, printing quality setting, printing data, etc., by altering the carriage operation, paper feed operation, etc.

By shifting the printing timing with multiple passes during printing, one raster is printed with multiple nozzles. The amount of ink ejected by each nozzle is kept constant to reduce irregular printing density. Also, smearing is less likely to occur since the freshly printed ink is fixed before the next ink is printed. Depending on the paper, up to eight passes can be executed for printing. (For the number of passes allowable in each mode, see [7.1 Print Modes](#).)

1.3.1 2-dot Pair + Bi-directional printing

In the case of conventional bi-directional printing, when for example cyan and magenta are mixed to produce blue, cyan is printed during the first pass and magenta is printed during the second pass. The color printed on the first pass always comes out stronger than the color printed on the second pass. The subtle difference in color between the first and second passes creates irregular printing between scans. To resolve this problem, the printer uses two nozzle arrays for each color to print each pixel at 600 dpi. The image is created with 2 dots, and the sequence of printing each dot is controlled.

In other words, the C2+M2 and M1+C1 portions to be printed during the first pass are mixed during a single scan. In the same way, the C1+M1 and M2+C2 portions to be printed during the second pass are mixed.

The difference in color caused by the printing sequence still occurs, however, it is not recognized as irregular printing because it changes at 1200 dpi intervals.

1.3.2 Seam stripe control

Seam stripe control suppresses the stripes created at the seams between passes. It aims to produce a high-quality image with a single pass.

For high-duty images where seam stripes are prone to occur between each pass, a dot-thinning process is executed. The degree of thinning to be implemented is determined when the user executes the print head position adjustment with the printer driver.

1.3.3 Rest between scans (Border detection control)

To prevent color smearing and a whitish color cast along the border between a color ink and black ink caused by the inks' differing characteristics, printing can be executed with a rest inserted between scans.

During the printer's internal print processing, the border between color and black inks is detected. When color ink is printed along a border with black ink, a wait is added for ink drying. The wait is set for each printing mode and each color. This reduces ink smearing.

Since this operation reduces the throughput, the user is able to select a rest between scans (a special setting) for only plain paper or postcards (when smearing is most prone to occur). It is executed if the print data includes borders between black and color inks.

1.3.4 Smear control and rest between pages

Both smear control and the rest between pages are for preventing smearing by the edge of the printed paper sliding against the preceding printed page.

If pigment ink is used for high-duty printing, smear control can delay the printing operation right before the next sheet of paper is stacked on the printed sheet. Smear control is executed by the printer controller. As for the rest between pages, the user can set it with the printer driver so that printing stops temporarily after each page is printed, regardless of the printing data. The smear control and rest between pages are independent operations. If both the smear control delay time and rest time between pages are set, a longer time will take effect.

1.3.5 Automatic power ON/OFF

The printer incorporates an automatic power ON/OFF feature. The printer turns on when it receives a printing signal from the computer, and it turns off automatically after a certain period of time when no printing signal is received. This feature can be set with the printer driver.

With automatic power ON enabled, the printer turns on automatically when 3 or more bytes of data is received continuously. The interface will remain operational even during power OFF. (Set with the EEPROM.)

With automatic power OFF enabled, the printer turns off when a set period of time elapses after the last printing data are sent by the computer. The printer does not turn off automatically in the following cases: An error has occurred, paper has been loaded into the manual feed slot, or when the front cover has been opened.

1.3.6 Print head protection from overheating

If ink runs out and the printing operation continues, the bubble jet head will overheat. To prevent overheating, overheating protection control takes effect if the head temperature sensor inside the bubble jet head detects an excessively high temperature.

1.3.7 Power motor control

Power motor control is for controlling the current to attain the following objectives:

(1) Reduction of current consumption during printing

The current is controlled so that the AC adapter's maximum output (momentary current) is not exceeded. By increasing the number of passes, current to heat the heater once is suppressed.

(2) The head's average current consumption is suppressed to restrain the power source's temperature increase.

Since the power source's temperature increases, it cannot be used while the average current is exceeded.

1.4 Detection Functions

1.4.1 Detection by sensors

The following sensors detect the printer's condition.

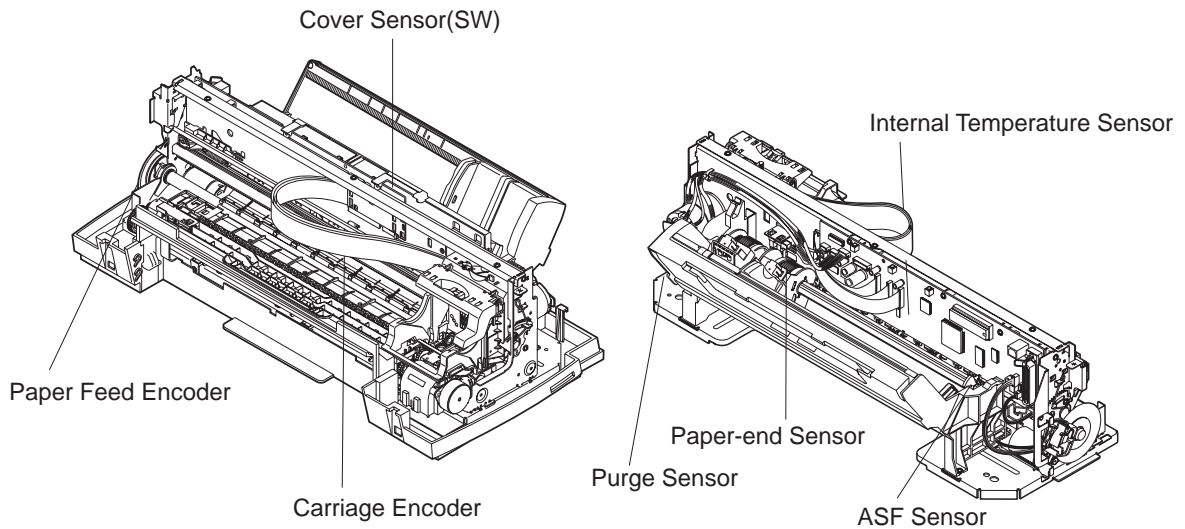

Figure 3-5 Location of Sensors

1.4.2 Paper-end sensor

The photo interrupter-type, paper-end sensor detects the paper with the paper sensor arm's flag when the edge of the paper passes through the paper feed section. When there is no paper, the sensor is closed by the paper sensor arm. When paper is detected, the sensor is open and paper is thereby detected.

1.4.3 Ink sensor (Same as for BJ F600)

Consisting of an LED and photo sensor, the ink sensor uses optical means to detect whether there is ink in the ink tank.

At the bottom of the ink tank is an indentation that works like a prism.

When there is ink in the ink tank, the refractive index of the ink and the prism's resin material is about the same. Therefore, the reflected amount of light is small.

When the ink is exhausted, the refractive index of the air and the prism's resin is very different, so all the light entering the sensor is reflected and the amount of reflected light is high.

The ink sensor detects the difference in the reflected light amount to determine whether or not there is ink in the tank. The MPU detects the voltage that changes according to the change in the reflected light amount. The analog value that is input is converted to a digital value by an internal A/D converter.

When the printer detects no ink in the ink tank, it indicates "ink low" on the status monitor for the respective ink tank. After the printer detects no ink in the ink tank, it starts to count the number of ejected dots corresponding to the amount of ink (about 20% of the ink amount) in the sponge and it starts to detect the no-ink error.

This error is detected in the following cases: While the power is ON, when the front cover is closed, after the pumping operation, or after the set number of dots have been printed. If the front cover is opened during the ink amount measurement, the external light may prevent an accurate measurement. The presence of an ink tank will also not be detected. If there is no ink tank, there will be no reflected light and the printer will therefore assume that there is ink.

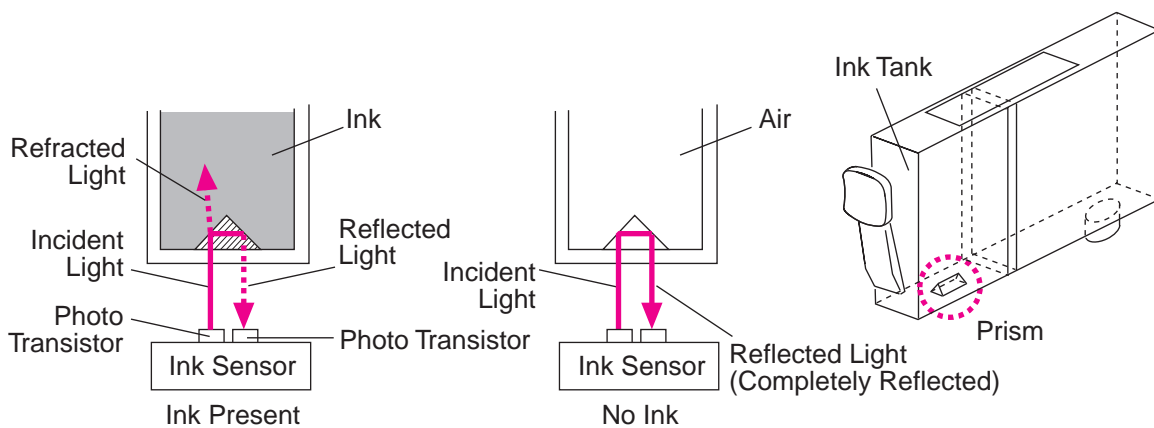

Figure 3-6 Ink Sensor

1.4.4 Cover sensor

The switch-type cover sensor detects whether the front cover is open or not. When the printer detects that the cover is open, it will move the carriage to the replacement position.

1.4.5 Pump sensor

The switch-type pump sensor detects the tube pump rotation's initial position. From the pump's initial position as detected by the printer, the printer will start to control the pumping operation.

1.4.6 Internal temperature sensor

The internal temperature sensor (TH201) on the control board detects the printer's internal temperature in order to control print head driving. When the printer's internal temperature changes, the thermistor's resistance also changes accordingly and the change in the resistance is detected by the MPU as a change in voltage. The analog value that is input is converted to a digital value by an internal A/D converter.

1.4.7 Head temperature sensor

The head temperature sensor is in the BJ cartridge's print head. If the head temperature is abnormally high, the sensor detects the head temperature and the abnormal head temperature error is issued to stop printing operation. When the head temperature changes, the diode sensor changes accordingly and the voltage change is detected by the MPU. The analog value that is input is converted to a digital value by an internal A/D converter.

1.4.8 ASF sensor

The ASF sensor detects the ASF paper feed rollers' initial position. It detects the paper feed rollers' position during ASF initial positioning and paper feeding.

1.4.9 Carriage encoder/paper feed encoder

With the encoder, the light from the LED passes through the encoder film and enters the photo IC. It is converted into a digital electrical signal when the encoder rotates or when the carriage moves.

With this feedback signal, the printer controls the driving of the DC motor.

1.5 Other Sensing Features

Besides the sensors described above, the printer has the following detection features.

1.5.1 Waste-ink detection

For print head maintenance, ink is ejected by the maintenance jet or purged by the recovery operation. The ejected or purged ink is absorbed by the waste-ink absorber. If the waste-ink absorber discharges ink because it contains more ink than it can absorb, the printer may leak ink.

To prevent ink from leaking, the waste-ink absorber's full capacity is detected by estimation.

The printer calculates the amount of waste ink produced by the maintenance jet and recovery operations by referring to the ink dot counter. While taking ink evaporation into account, if the estimated waste-ink amount exceeds 95% of the waste-ink absorber's capacity, the waste-ink warning is issued when the power is turned on. If the estimated waste-ink amount reaches 100% of capacity, the waste-ink full error occurs.

1.5.2 Print head detection

The presence of the print head is detected with the AD value obtained from the head temperature sensor. If the temperature counted in reverse from the AD value is lower than the absolute 0 degree (an impossible value), the printer will assume that there is no print head.

2. ELECTRICAL DRIVE SECTION

The electrical drive section controls the electrical components in accordance with the control signals and control data received from the control section.

2.1 Block Diagram

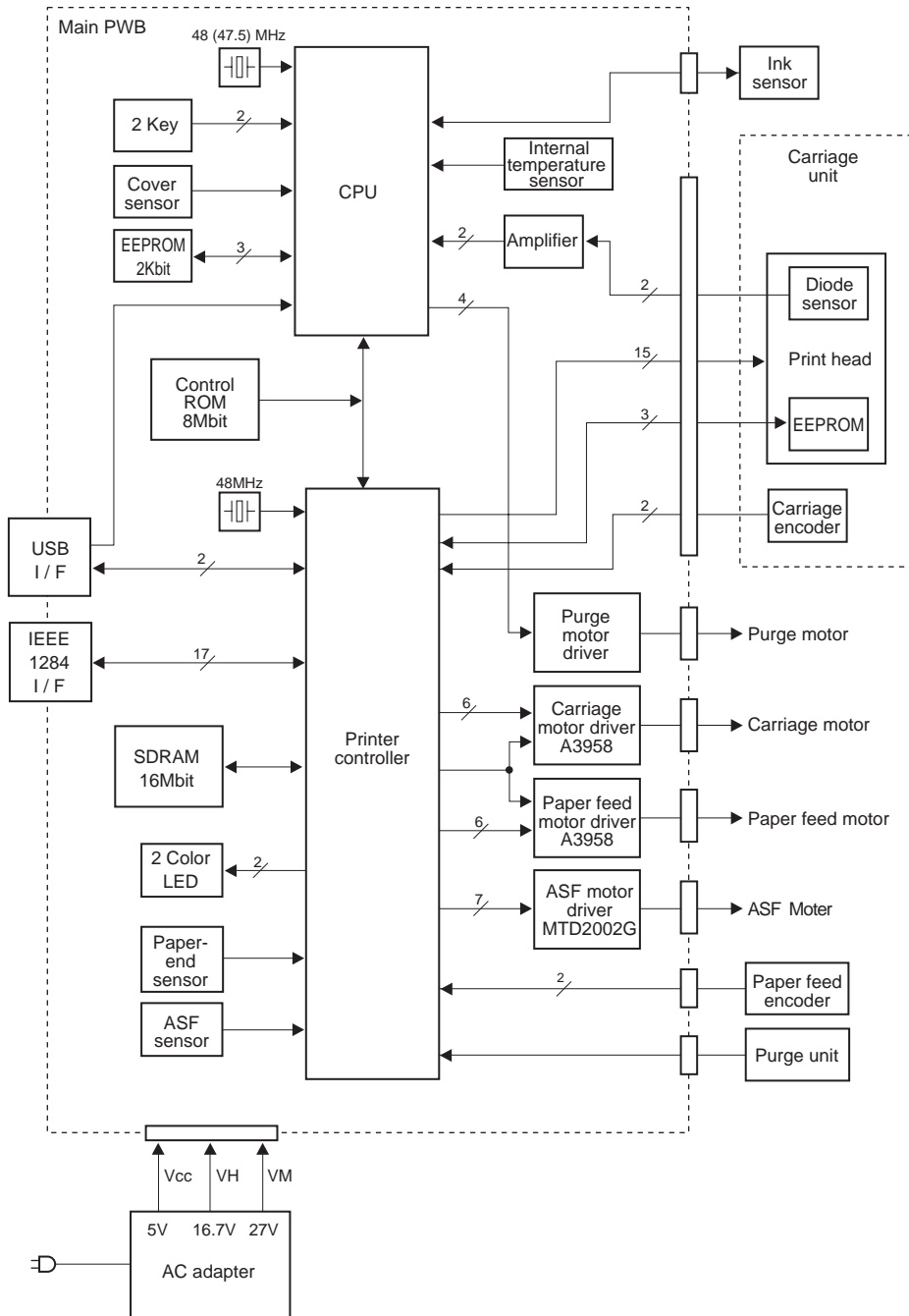

Figure 3-7 Block Diagram

2.2 Electrical Section

To supply a driving voltage to the motor, IC, BJ cartridge, etc., the electrical section converts the AC voltage received from the AC power source into DC voltage.

a) AC adapter

The AC adapter converts the voltage from the AC power source into three voltages: +27 VDC, +19 VDC, and +5 VDC.

The +27 VDC's output is controlled according to the signal (DWCONT) output by the printer controller.

The +27 VDC is used as LF, CR, ASF, and PG for the respective motor drive power source.

The +19 VDC is the print head's heater driving power source.

The +5 VDC is the logic system's power source. It is constantly supplied by the AC adapter. As a result, as long as AC power is being supplied, all the hardware except the sensors, driver IC, and BJ cartridge are in the active state.

b) DC/DC converter

The DC/DC converter on the control board converts the voltage into +5 VDC and +3.3 VDC and outputs both.

The +5 VDC is used for the EEPROM and reset driving power source and the power voltage for the HVDD, VIF, and VSEN. The HVDD, VIF, and VSEN power voltage outputs are controlled by the printer controller.

Also, the +5 VDC is used as the power source for the printer controller, MPU, DRAM, and control ROM. It is also used as a pull-up power source for various switches.

By using +3.3 VDC as the power source, the power consumption during power off is less than when +5 VDC is used.

3. PRINTER'S MECHANICAL PARTS

3.1 Overview of the Printer's Mechanical Parts

The printer's mechanical parts consist of the BJ cartridge, carriage, purge section, and paper feed section. Each part is explained below.

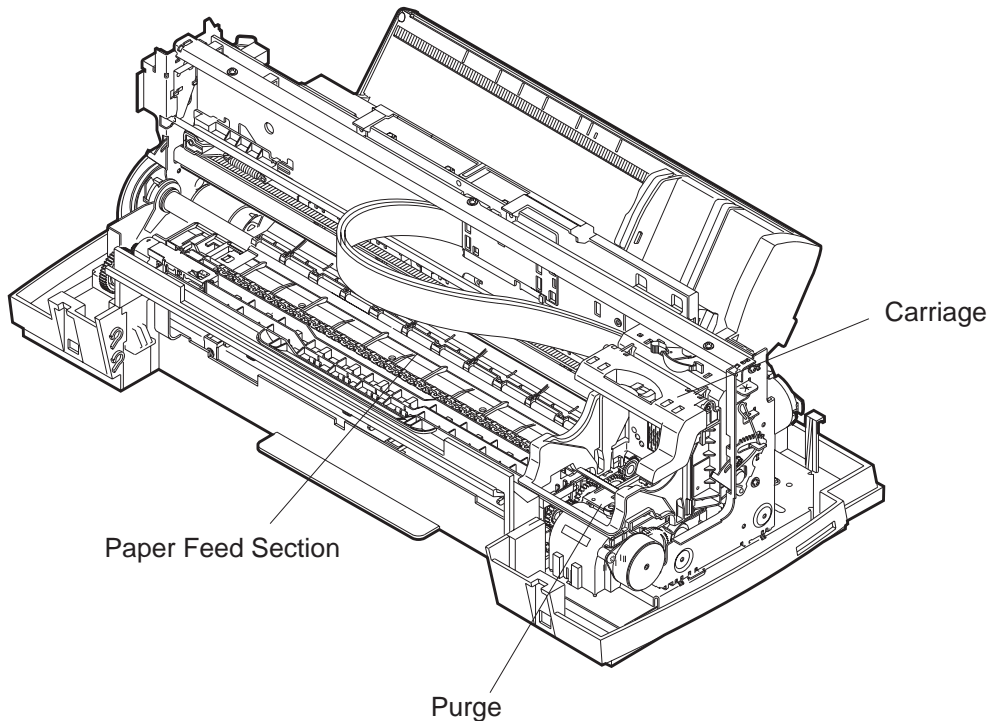

Figure 3-8 Printer's Mechanical Parts

3.1.1 Carriage

The carriage holds one BJ cartridge in place. The carriage belt driven by the carriage motor (DC motor) moves the carriage horizontally back and forth across the paper. Regarding the carriage's position control, the initial position is detected when the carriage goes against the right wall which is the home position. After that, the carriage position is detected by reading the pulse from the encoder film. The paper spacing position is read from the carriage position when the carriage goes against the left wall.

3.1.2 Purge section

The purge section, driven by a dedicated purge motor, consists of the wiper, pump, cap, and carriage lock.

The wiper maintains the head face surface to ensure high-quality printing. The ink suction feature enables the ink to be readily ejected from the nozzles.

When the BJ cartridge is not in use, the nozzles are protected by a cap, and the carriage is locked in place.

The motor's running direction controls the ink suction operation or capping/wiping/valve open/closing operation.

3.1.3 Paper feed section

The paper feed section consists of the paper feed components, paper transport section, and paper discharge section.

Paper feed

Paper is fed automatically by the auto sheet feeder.

The auto sheet feeder is driven by the paper feed motor. Paper of various sizes up to legal size can be stacked and fed automatically (the paper is transported to the paper transport section).

Paper transport section

The paper feed section, driven by the paper feed motor, keeps the sheet of paper flat and horizontal on the platen and rotates the feed roller to move the paper horizontally to and beneath the print head.

Paper eject section

After printing, paper is ejected onto the discharge tray by the eject rollers.

After the sheet of paper leaves the paper feed rollers, the eject rollers take over to eject the paper.

3.2 Purge Section

3.2.1 Purge section functions

In order to maintain good printing quality, the purge section maintains the BJ cartridge's nozzles. The purge section's functions consist of capping and cleaning.

a) Capping

The purge unit's cap is pressed against the print head's face to protect the nozzles from dust, etc., and to prevent the nozzles from drying out. To prevent the capping position from shifting, the carriage is locked in place at the same time.

When the cap is open while the printer is on standby for printing and a certain period of time elapses (55 sec. with no paper or 20 min. with paper loaded), the print head will be capped automatically. You can also cap the print head by pressing the *POWER* button to turn off the printer.

b) Cleaning

Cleaning executes the following operations:

Wiping: Paper residue and dried ink on the print head's face plate are wiped off.

Suction: The ink is sucked out of the print head to refresh the nozzles with new ink.

Maintenance jet: To eliminate any air bubbles in the head's nozzles and to remove waste particles near the nozzle openings, ink is ejected from the nozzles onto the cap and maintenance jet receptacle.

Cleaning is performed at the times below to ensure that the head produces high-quality printing.

3.2.2 Purge section components

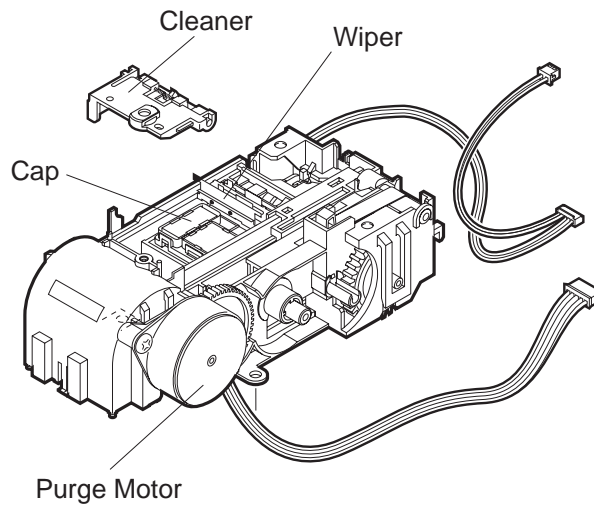

Figure 3-9 Purge Section Components

a) Purge driving motor

The purge motor drives the wiper, carriage lock, and pump. It is a constant-voltage motor operating with a 1-2 phase drive.

b) Wiper

The wiper consists of a wiper and wiper cleaner.

The wiping operation is executed while the carriage is fixed at the purge section. It wipes the print head's nozzle array in a vertical motion.

c) Cap

The rubber cap protects the print head (capping operation) and sucks out (pumping operation) the ink in the cap.

When the carriage moves to the capping position, the cap is pressed against the print head's face plate. There is a different cap for the black and color print heads. An ink tube connects the rubber cap to the pump and air valve.

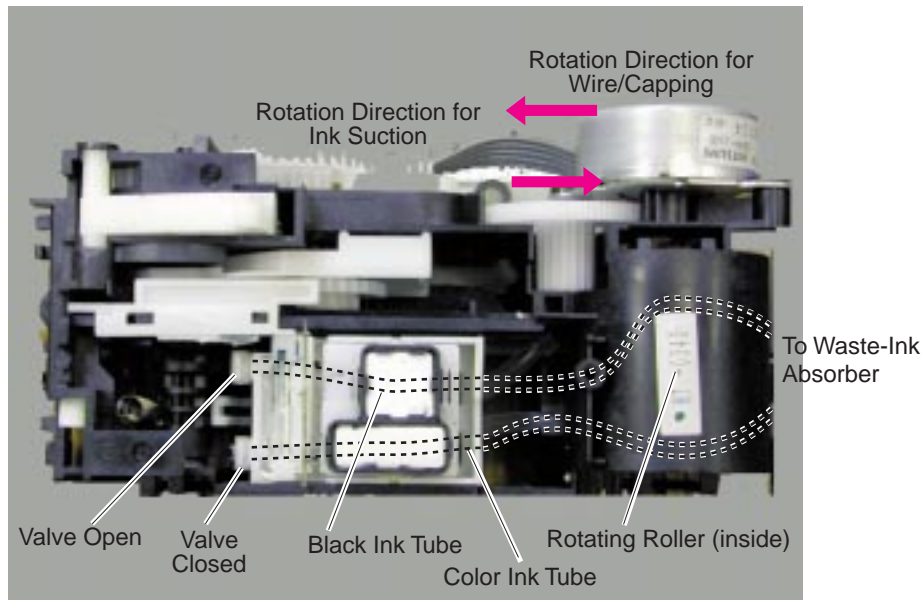

Figure 3-10 Pump Operation

d) Pump

This is a tube pump system consisting of two ink tubes (one for black and one for color) pressurized by a rotating roller. A negative pressure is thereby created to suck the ink. Inside, there is a valve dedicated to black ink and one dedicated to color ink. When the valves close or open separately or simultaneously, only the black ink (color valve open) or color ink (black valve open) can be sucked or both inks can be sucked (black and color valves closed).

The amount of ink sucked can be high, medium, or low depending on how much the roller rotates.

The pumping operation is executed with the rotation of the roller after the carriage is released from the capping position and both valves are opened.

The degree of rotation of the pump's roller and the timing of the rotation are controlled by the step count in accordance with the initial position detected by the pump sensor.

The two tubes are placed right before the waste-ink absorber. By mixing pigment ink and dye ink, ink hardening is prevented.

3.3 Paper Feed Section

3.3.1 Paper feed components

The paper feed components include an ASF incorporating a friction separation system which uses a separation pad. Compared to previous ASF systems, it has a very strong paper feed force.

It consists of the following parts: Paper feed roller and separation pad, pressure roller and return corner, pressure plate, motor, and sensor.

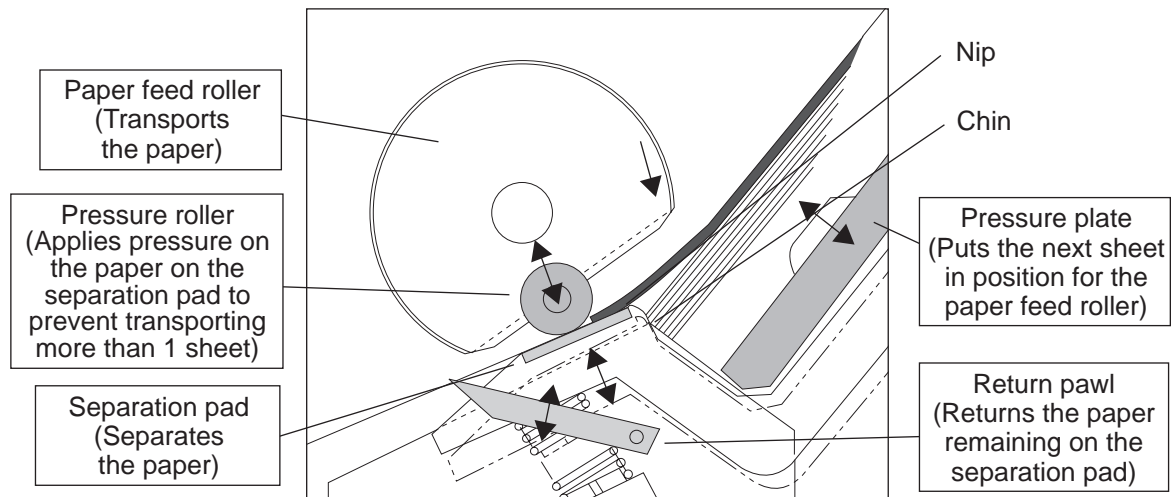

Figure 3-11 Paper Feeding

The motor is a constant-current stepping motor. It drives the paper feed roller with 1-2-phase driving. There is a sensor on the paper feed roller to detect the paper feed roller's initial position.

The pressure roller and return corner prevent the paper that could not be completely separated by the separation pad from proceeding to the paper transport section. The pressure roller presses down the sheet of paper that is on the separation pad. It prevents multiple sheets from being transported. The paper therefore has a back tension (counteracting force against the feed roller's pulling force on the paper). Also, the return corner is for returning the paper remaining on the separation pad. The timing for returning the paper changes depending on the paper type and length selected with the printer driver.

3.3.2 Friction separation system

The friction separation system's paper separation method is explained below.

1. When the paper feed roller turns, the top sheet of the paper stack is taken to the nip where the pressure roller contacts the paper feed roller.
2. When the top edge of the paper reaches the nip, the paper pushes down the pad by the amount of the paper's thickness. At this point, since the frictional force between the paper and separation pad is less than the frictional force between the paper and paper feed roller, the paper feed roller further transports the paper into the printer.
3. At this time, the next sheet of paper stops at the chin.
4. If the next sheet of paper could not be stopped at the chin in step 3, it will be stopped on the separation pad because the frictional force between the paper sheets is less than the frictional force between the paper and separation pad. Only the top sheet is therefore sent into the printer.

3.3.3 Paper transport section

At the printing section, an unchanging gap between the paper and print head is maintained while the paper is pressed against the platen as it goes between the pressure roller and paper feed roller and between the spur and eject roller.

For paper transport control during printing, a metallic, high-precision paper feed roller having a coat of ceramic paint and an optical encoder film affixed on it is used. The paper feed roller is driven by a DC motor via a belt. The paper transport is controlled according to the signal read from the encoder film. The paper is transported in 1/1440-inch increments.

3.3.4 Paper discharge section

While the sharp-tipped spurs press down the printed side of the paper (without marking it) against the eject rollers, the eject rollers discharge the printed paper.

The paper discharge section consists of the eject rollers and spurs. A sheet of paper fed to the print starting position is printed on as it goes over the platen. The paper is transported by the paper feed and pinch rollers. When printing is completed, the paper is ejected by the eject rollers and spurs, with the paper eject support function (*1) enabled to prevent smearing.

*1: The function is enabled when B5 or larger sized plain paper is selected and the Print Quality is set to "Standard" or "High" in the printer driver.

4. LOGIC BOARD COMPONENTS

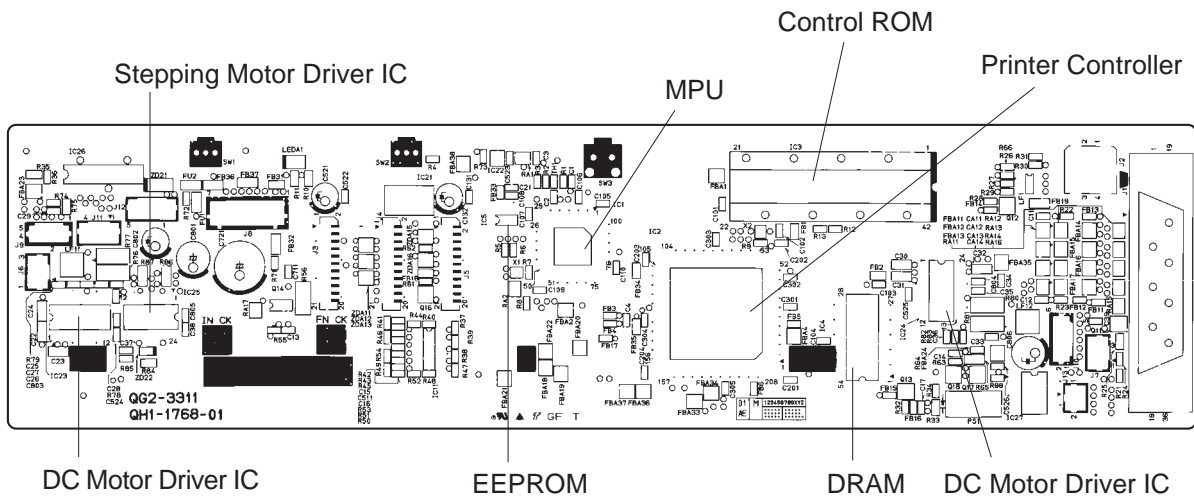

Figure 3-12 Control Board

a) Printer controller (IC2)

The printer controller has the following eight functions. It operates with a 48 MHz external clock (not synchronized with the CPU).

1. I/F control

The data is transferred with a serial (USB 1.1 standard) or parallel (IEEE 1274 standard) transmission. Parallel transmissions operate in the compatible, nibble, and ECP modes.

2. Receiving buffer control

The ring buffer-type receiving buffer and the straight-type transmission buffer are controlled.

3. System management enabled

With the built-in timer, any clock stoppage or suction time is counted. Also the status of the port in the printer controller is sampled.

4. Data decompression

The data compressed by the printer driver is restored as print data. In addition, during printing in the HS mode, 300 dpi data is expanded by 2× vertically and horizontally to 600 dpi. The CMY 2-bit data is also distributed to the even/odd buffers for each even/odd array on the print head.

5. Data processing

A dot count is executed for power monitoring and smear processing. Also, dot thinning for seam stripe processing is based on the dot count and color tone.

6. Printing control

The data received is rearranged in the raster direction.

Also, data is processed so that the print head's heaters are heated in the suitable sequence.

7. Print head control

Serial print data is sent to the print head.

The transfer clock is 6 MHz. Since data latch occurs at the clock's start-up and shutdown, the data transfer speed is faster.

Also, the print head heater's heating is executed with a single pulse or double pulse. In the case of a double pulse, the first pulse is a press pulse. The pulse following it becomes the main pulse.

The print head's temperature is estimated with the dot count. Based on the estimated temperature, suitable heating is executed with the voltage value.

8. Motor control

The encoder signals input from the two DC motors are processed, and a signal for the 1-2-phase driving of the auto sheet feeder motor is generated.

b) MPU (IC1)

The MPU contains a 32-bit CPU, 16 KB work RAM, 21-bit address bus port, 16-bit data bus port, interrupt controller, A/D converter, I/O port, and other built-in components. With the chip select signal, the MPU selects the control ROM, printer controller, and DRAM.

Built-in CPU

The 32-bit CPU operates in synchronization with a 48 MHz external clock input.

Address bus/Data bus

This operates in synchronization with a 20 MHz external clock input. An external RAM (16 Mbit) is accessed via the 16-bit data bus.

Interrupt controller

The MPU receives external interrupts from the *POWER* button's ON/OFF and I/F.

A/D converter

The following analog signals are detected after they pass through the built-in A/D converter.

Resume key input

EEPROM data I/O

EEPROM chip select output

Door sensor input

CSB power input

Sensor (purge, paper end, sheet feeder) inputs

LED (ERROR/POWER) outputs

I/F (Centronics/CSB) pull-up control I/O

Print head power control (ON/OFF)

(VDD/VH)

Ink sensor power control (ON/OFF)

Purge motor control (4 ports, A/B/A/B phase)

I/O port

The I/O port executes the following control operations.

c) DRAM (IC4)

The 16 Mbit DRAM is controlled by the printer controller and used as a receiving buffer, download buffer, print buffer, and working area.

d) DC motor driver (IC23/24)

The motor driver IC is for driving the DC motor (paper feed motor and carriage motor). This driver is a PWM (pulse-width modulation) IC that changes the current's pulse width to control the output. It thereby controls the motor. The pulse-width control is defined by the serial data (10 bit) from the printer controller.

e) EEPROM (IC5)

The 2 Kbit EEPROM controlled by the printer controller records the waste-ink absorption amount, page count, and BJ cartridge removal/installation count. The printer reads the EEPROM contents when AC power is supplied and records the data when the power is turned off.

f) Control ROM (IC3)

The 8-bit control ROM is written with a printer control program.

g) Stepping motor driver IC (IC25)

This is a driver IC for constant-current driving of the ASF motor. The driving method is 1-2-phase driving.

5. OPERATION WITH A COMPUTER

For printer operation with a computer, printing with the printer driver's "Basic Setting Sheet" and setting the "Utility Sheet" are explained below.

5.1 Printing Operation with the Basic Settings Sheet

To enable the user to print easily, the printer driver's ease of use has been improved. The Basic Settings Sheet enables the user to set the paper type, paper feed method, and printing quality.

Also, the "Print Advisor" is a new feature. When the user does not know which paper is suitable for printing, the Print Advisor gives on-screen instructions so that the optimum settings are selected automatically.

5.2 Using the Utility Sheet

This enables the usual operations such as cleaning, print head refreshing, print head position adjustment, nozzle check pattern printing, power OFF, automatic power setting, and special settings (economy cleaning, smear control, ECP, etc.) for status monitor start-up.

When printing is executed for a large amount of data and the ECP mode check is off, the printing speed decreases.

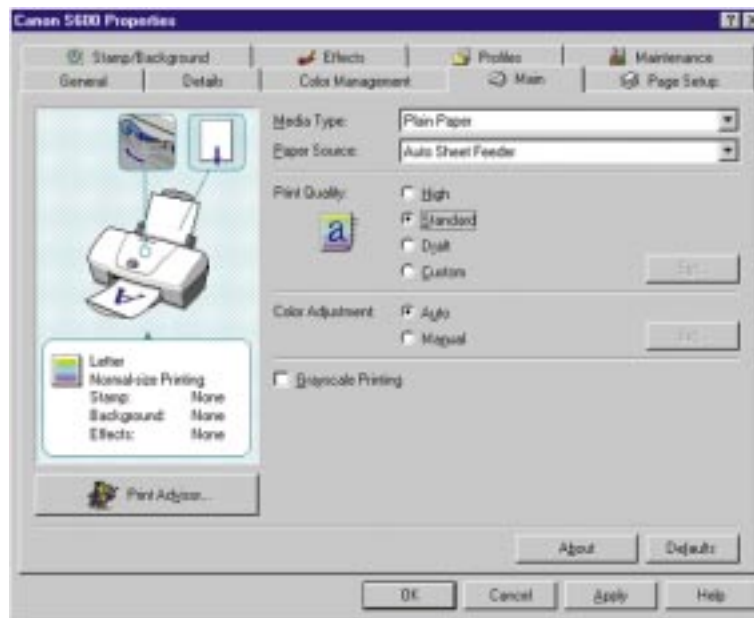

Figure 3-13 Basic Settings Sheet (Sample)

6. INK SUCTION AMOUNT IN THE CLEANING MODE

The printer has five cleaning modes (A to G). Cleaning is executed for maximum effectiveness and efficiency. The cleaning operation is selected depending on the respective condition. The ink suction operation differs depending on the condition at three occasions: Operation by the user, cover open/closing, and before printing starts.

- Operation by the user: Manual ink suction (Including printer driver operation)
- Cover open/closing: Cleaning at printer arrival
- Before printing starts: Other than manual suction

Mode			Suction Amount (g)	Precondition*
Cleaning A	All colors	Bk+Cl	0.15+0.36	Dot count suction, Manual suction (All colors) ^{*2} , timer suction (Time not set) ^{*4}
	Bk	Bk	0.15	Dot count suction, Manual suction (Bk) , timer suction (60 ^{*5} ~ 336 h)
	Cl	Cl	0.36	Dot count suction, Manual suction (Cl) , timer suction (120 ~ 336 h)
Cleaning D	All colors	Bk+Cl	0.3+0.72	Tank replacement ^{*3} after soft power ON (All colors)
	Bk	Bk	0.3	Tank replacement ^{*3} after soft power ON (Bk)
	Cl	Cl	0.72	Tank replacement ^{*3} after soft power ON (Cl)
Cleaning E	All colors	Bk+Cl	0.45+0.72	Long timer suction (336 h ~)
Cleaning F	All colors	Bk+Cl	0.45+1.08	When print head is replaced, at printer arrival
Cleaning G	All colors	Bk+Cl	1.5+1.08	Head refreshing

*1 If the preconditions overlap, the stronger suction will take priority.

Cleaning A < Cleaning D < Cleaning E < Cleaning F < Cleaning G

*2 In the case of the boxed preconditions, the suction starts right after the precondition is executed. For other preconditions, suction is executed right before the printing starts or during printing.

*3 Ink tank replacement is detected when the ink tank's status changes from H to L.

*4 Printing of EEPROM contents, etc., with the printer alone.

*5 Purging operations will be performed after 24 hours only the first 5 times, after which purging will occur at 60 to 336 hours intervals.



When checking the functions of the purge unit, measure the suction amount for a manual suction.

7. TECHNICAL REFERENCE

7.1 Printing Mode List

The printing mode list for the black, color, and photo BJ cartridges is shown below. By setting the printer driver's "Dithering," "Paper Type," and "Printing Quality," the printer will operate in the printing modes below.

Table 3-1 PRINTING MODE LIST

Monochrome Printing

Paper Type	Resolution (dpi)							Default
	Bk=600 × 600	Bk=600 × 600	Bk=600 × 600	/	Bk=600 × 600	/	/	
Plain Paper	1Pass-Bi PigBk	1Pass-Bi PigBk			4pass-Bi PigBk			(High/Stand- ard/Fast)
Postcard		2Pass-Uni PigBk	4Pass-Uni PigBk					Standard/ Fast
Ink-jet P.O. Postcard		2Pass-Uni PigBk	4Pass-Uni PigBk					Standard/ Fast

Color Printing

Paper Type	Resolution (dpi)							Default
	Bk=600 × 600 Y=600 × 1200 CM=1200 × 1200	Bk=600 × 600 Y=600 × 1200 CM=1200 × 1200	Bk=600 × 600 Y=600 × 1200 CM=1200 × 1200	CMY=1200 × 1200	Bk=600 × 600 Y=600 × 1200 CM=1200 × 1200	CMY=1200 × 1200	CMY=1200 × 1200	
Plain Paper	1Pass-Bi PigBk	1/4 Pass-Bi PigBk			4pass-Bi PigBk			(High/Stand- ard/Fast)
OHP Transparency		2Pass-Bi PigBk	4Pass-Bi PigBk+YMC					Standard/ High
T-shirt Heat Transfer Paper				6Pass-Bi YMC				Standard
Glossy Paper/ Glossy Postcard				4Pass-Bi YMC		6Pass-Bi YMC		Standard/ High
Glossy Film						4Pass-Bi YMC	6Pass-Bi YMC	Standard/ High
High-quality Paper				4Pass-Bi YMC		6Pass-Bi YMC		Standard/ High
Postcard/ Envelope		3Pass-Bi PigBk+YMC	4Pass-Bi PigBk+YMC					Standard/ High
Pro Photo Paper Photo Card						4Pass-Bi YMC	6Pass-Bi YMC	Standard/ High
Ink-jet P.O. Postcard		2Pass-Bi YMC	4Pass-Bi YMC					Standard/ High

Bk : Black **PigBk** : Pigment black **Bi** : Bi-directional
C : Cyan **YMC** : Processed black **Uni** : Uni-directional
M : Magenta
Y : Yellow

 The shaded specifications are the default for the respective media.

8. PRINT HEAD

The two nozzle arrays for each CMY color are divided symmetrically left and right along the M line. This makes it completely compatible with bi-directional printing.

Also, the relative position of the two nozzles is shifted by 600 dpi for black and by 1200 dpi for color. Thus, the two nozzles together on a single pass produce 600 dpi resolution for black and 1200 dpi resolution for color.

There is a heater near the nozzle openings and small ink drops are ejected with a strong force.

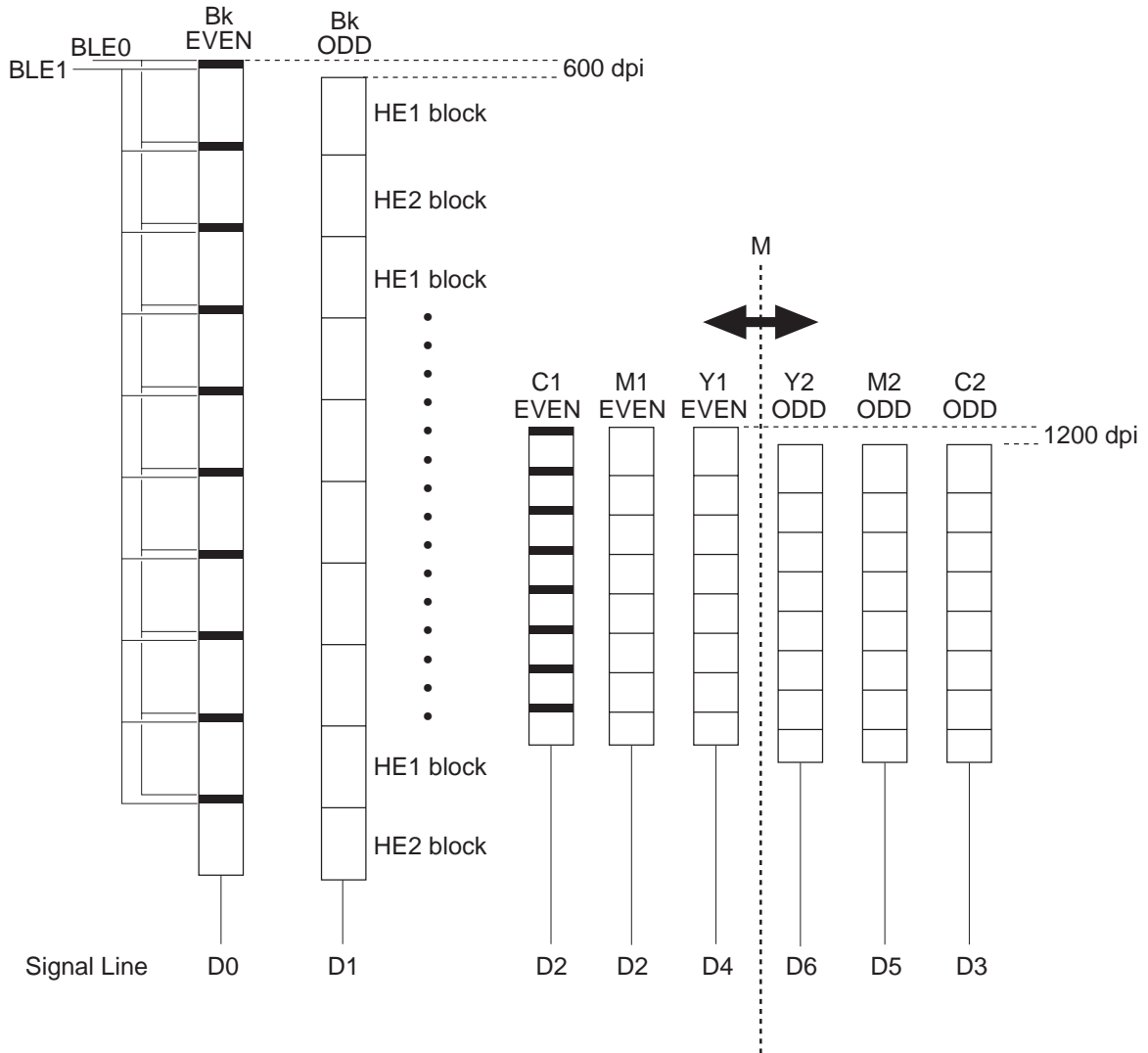

Product Specifications

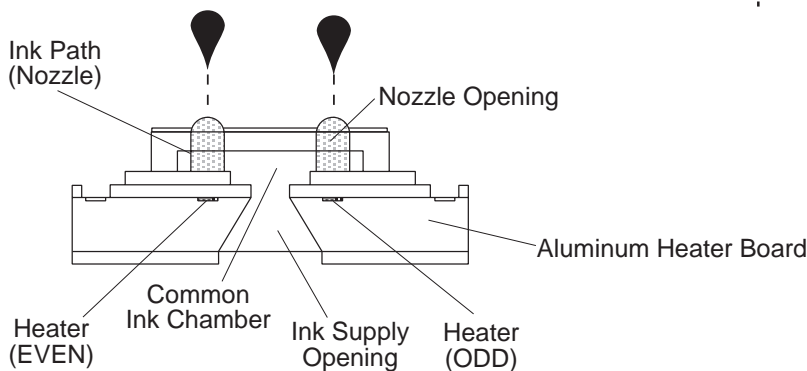

Figure 3-14 Nozzle Array

This page intentionally left blank



Part 4

APPENDIX

Page	
4 - 1	1. CONNECTOR LOCATIONS AND PIN CONFIGURATIONS
4 - 5	1.1 Carriage Board
4 - 7	1.2 Print Head
4 - 8	2. Circuit Diagram

1. CONNECTOR LOCATIONS AND PIN CONFIGURATIONS

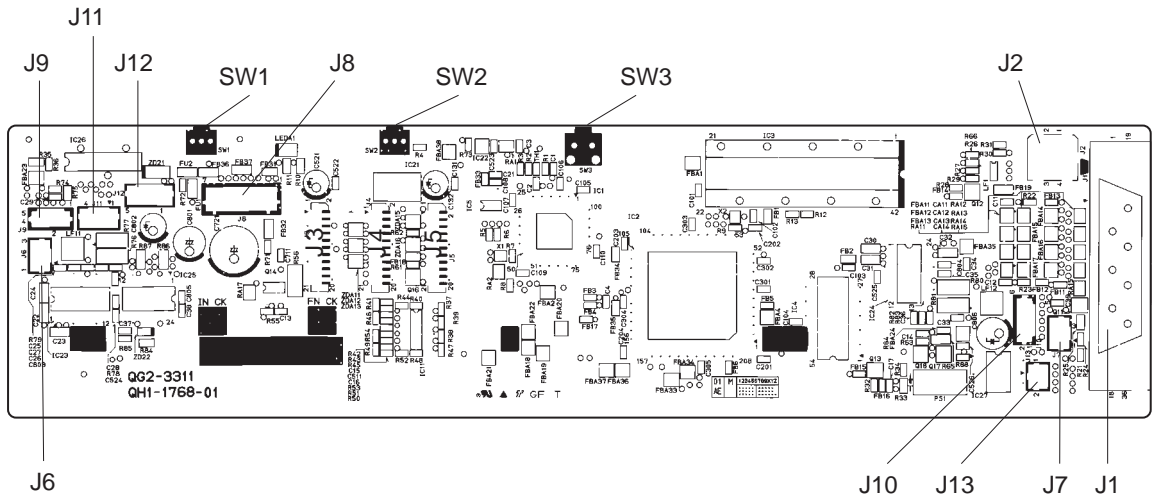

Figure 4-1 Control Board

J1 (Parallel Interface Connector)

Pin No.	Compatible Mode	Nibble Mode	ECP Mode
1	STROBE	HostClk	HostClk
2	DATA1	Data1	Data1
3	DATA2	Data2	Data2
4	DATA3	Data3	Data3
5	DATA4	Data4	Data4
6	DATA5	Data5	Data5
7	DATA6	Data6	Data6
8	DATA7	Data7	Data7
9	DATA8	Data8	Data8
10	ACKNLG	PrtClk	PeriphClk
11	BUSY	PrtBusy	PeriphAck
12	P.E.	AckDataReq	AckReverse
13	SELECT	Xflag	Xflag
14	AUTO FEED XT	HostBusy	HostAck
15	N.C	Undefined	Undefined
16	GND	Gnd	Gnd
17	GND	Gnd	Gnd
18	+5.0V	Vcc	Vcc
19	STROBE-RET (GND)	Signal Gnd	Signal Gnd
20	DATA1-RET (GND)	Signal Gnd	Signal Gnd
21	DATA2-RET (GND)	Signal Gnd	Signal Gnd
22	DATA3-RET (GND)	Signal Gnd	Signal Gnd
23	DATA4-RET (GND)	Signal Gnd	Signal Gnd
24	DATA5-RET (GND)	Signal Gnd	Signal Gnd
25	DATA6-RET (GND)	Signal Gnd	Signal Gnd
26	DATA7-RET (GND)	Signal Gnd	Signal Gnd
27	DATA8-RET (GND)	Signal Gnd	Signal Gnd
28	ACKNLG-RET (GND)	Signal Gnd	Signal Gnd
29	BUSY-RET (GND)	Signal Gnd	Signal Gnd
30	P.E.-RET (GND)	Signal Gnd	Signal Gnd
31	INIT	INIT	ReverseReq
32	ERROR	DataAvail	PeriphReq
33	GND	Undefined	Undefined
34	N.C	Undefined	Undefined
35	+5.0V	Undefined	Undefined
36	SELECT IN	1284Active	1284Active

J2 (USB Interface Connector)

Pin No.	Signal	IN/OUT	Function
1	PWR	IN	Cable power source
2	D -		Data
3	D +		Data
4	GND	...	Cable GND

J6 (Paper-Feed Motor Connector)

Pin No.	Signal	IN/OUT	Function
1	VSNS	IN	
2	GND
3	SNS_PE	IN	Signal by paper end lever

J7 (Ink Sensor Connector)

Pin No.	Signal	IN/OUT	Function
1	INK_PWM	OUT	Photo LED drive signal in the ink sensor
2	GND
3	INKS	IN	Voltage varies according to the reflected light amount

J8 (DC Power Source Connector)

Pin No.	Signal	IN/OUT	Function
1	+5V	IN	+5VDC
2	+5V-GND	...	GND
3	VH	IN	+19V
4	VH-GND	...	GND
5	VM	IN	+27VDC
6	VM-GND	...	GND
7	NC	...	NC

J9 (Pump Sensor Connector)/Carriage Motor Connector

Pin No.	Signal	IN/OUT	Function
1	VSEN	OUT	Photo LED drive signal in the ink sensor
2	GND
3	SNS_PG	IN	Pump sensor sense signal High (sense)/Low
4	CRA	OUT	Carriage motor phase A
5	CRB	OUT	Carriage motor phase B

J10 (LF Motor Connector)

Pin No.	Signal	IN/OUT	Function
1	OUT_A	OUT	LF motor phase A
2	OUT_B	OUT	LF motor phase B
3	GND	IN	GND
4	LF_ECA	IN	LF encoder phase A
5	VSNS	IN	
6	LF_ECB	IN	LF encoder phase B

J11 (ASF Motor Connector)

Pin No.	Signal	IN/OUT	Function
1	ASF A	OUT	ASF motor phase A
2	ASF B	OUT	ASF motor phase B
3	$\overline{\text{ASF A}}$	OUT	ASF motor phase $\overline{\text{A}}$
4	$\overline{\text{ASF B}}$	OUT	ASF motor phase $\overline{\text{B}}$

J12(Purge Motor Connector)

Pin No.	Signal	IN/OUT	Function
1	+27	OUT	+2VDC
2	PG A	OUT	PG motor phase A
3	$\overline{\text{PG A}}$	OUT	PG motor phase $\overline{\text{A}}$
4	PG B	OUT	PG motor phase B
5	$\overline{\text{PG B}}$	OUT	PG motor phase $\overline{\text{B}}$

1.1 Carriage Board

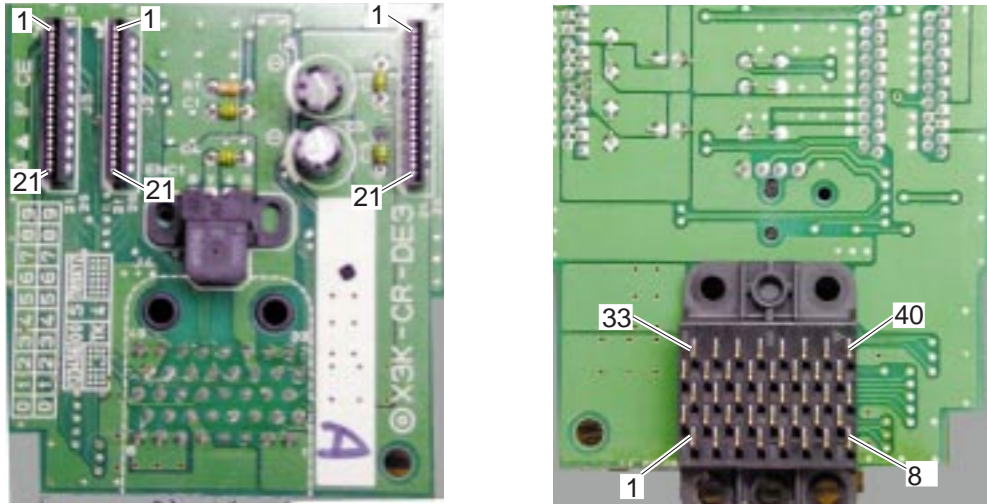

Figure 4-2 Carriage Board

J1 (Carriage Ribbon Cable Connector)

See page 4-6 (J3 Carriage Ribbon Cable Connector Pin Description).

J2 (Carriage Ribbon Cable Connector)

See page 4-6 (J4 Carriage Ribbon Cable Connector Pin Description).

J3 (Carriage Ribbon Cable Connector)

See page 4-6 (J5 Carriage Ribbon Cable Connector Pin Description).

J4 (Print Head)

Pin No.	Signal	IN/OUT	Function
1~40			See page 4-7 (Print Head Pin Description)

J3 (Carriage Ribbon Cable Connector) ↔ J1: Carriage Board

Pin No.	Signal	IN/OUT	Function	J1 Pin No.
1	VHT	OUT	Power transistor driving power source (19 V) in the print head	Same as J3 pin No.
2~6	B_VH	OUT	Color heater driving voltage (19 V)	
7~11	A_VH	OUT	Black heater driving voltage (19 V)	
12~16	B_GND	...	GND (for color heater driving voltage)	
17~21	A_GND	...	GND (for black heater driving voltage)	

J4 (Carriage Ribbon Cable Connector) ↔ J2: Carriage Board

Pin No.	Signal	IN/OUT	Function	J1 Pin No.
1, 2, 3, 7, 9, 11, 14, 16, 19	SUBHO	OUT	Black secondary heater driving signal	Same as J4 pin No.
	GND	...	Logic ground	
4	H_ENB1	OUT	Color nozzle heat enable signal (Even/odd array's odd block)	
5	H_ENB2	OUT	Color nozzle heat enable signal (Even/odd array's even block)	
6	H_ENB0	OUT	Black nozzle heat enable signal	
8	H_LATCH	OUT	Data latch enable signal	
10	H_CLK	OUT	Clock signal	
12	H_D0	OUT	Black even array nozzle data signal	
13	H_D1	OUT	Black odd array nozzle data signal	
15	ENCA	IN	Carriage encoder signal	
17	ENCB	IN	Carriage encoder signal	
18	VSEN	OUT	Carriage encoder sensor power source	
20	DIA0	IN	Head temperature sensor's (diode) anode side (black)	
21	DIK0	...	Head temperature sensor's (diode) cathode side (black)	

J5 (Carriage Ribbon Cable Connector) ↔ J3: Carriage Board

Pin No.	Signal	IN/OUT	Function	J1 Pin No.
1, 2	SUBHO	OUT	Color secondary heater driving signal	Same as J5 pin No.
3, 7, 11, 19	GND	...	Logic ground	
4	H_D2	OUT	Cyan even array nozzle data signal	
5	H_D3	OUT	Cyan odd array nozzle data signal	
6	H_D4	OUT	Magenta even array nozzle data signal	
8	H_D5	OUT	Magenta odd array nozzle data signal	
9	H_D6	OUT	Yellow even array nozzle data signal	
10	H_D7	OUT	Yellow odd array nozzle data signal	
12	H_EEPROM_CS	OUT	EEPROM chip select signal in the print head	
13	H_EEPROM_SK	OUT	EEPROM serial data clock signal in the print head	
14	H_EEPROM_D	OUT	EEPROM serial data signal in the print head	
15~18	HVDD	OUT	Logic power source in the print head	
20	DIA1	IN	Head temperature sensor's (diode) anode side (color)	
21	DIK1	...	Head temperature sensor's (diode) cathode side (color)	

1.2 Print Head

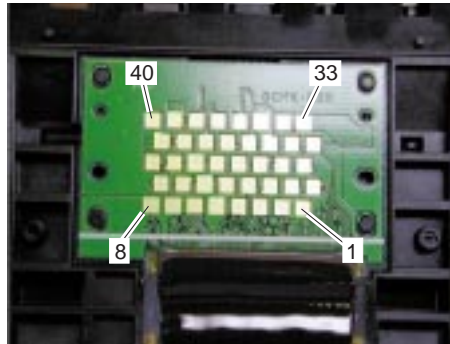
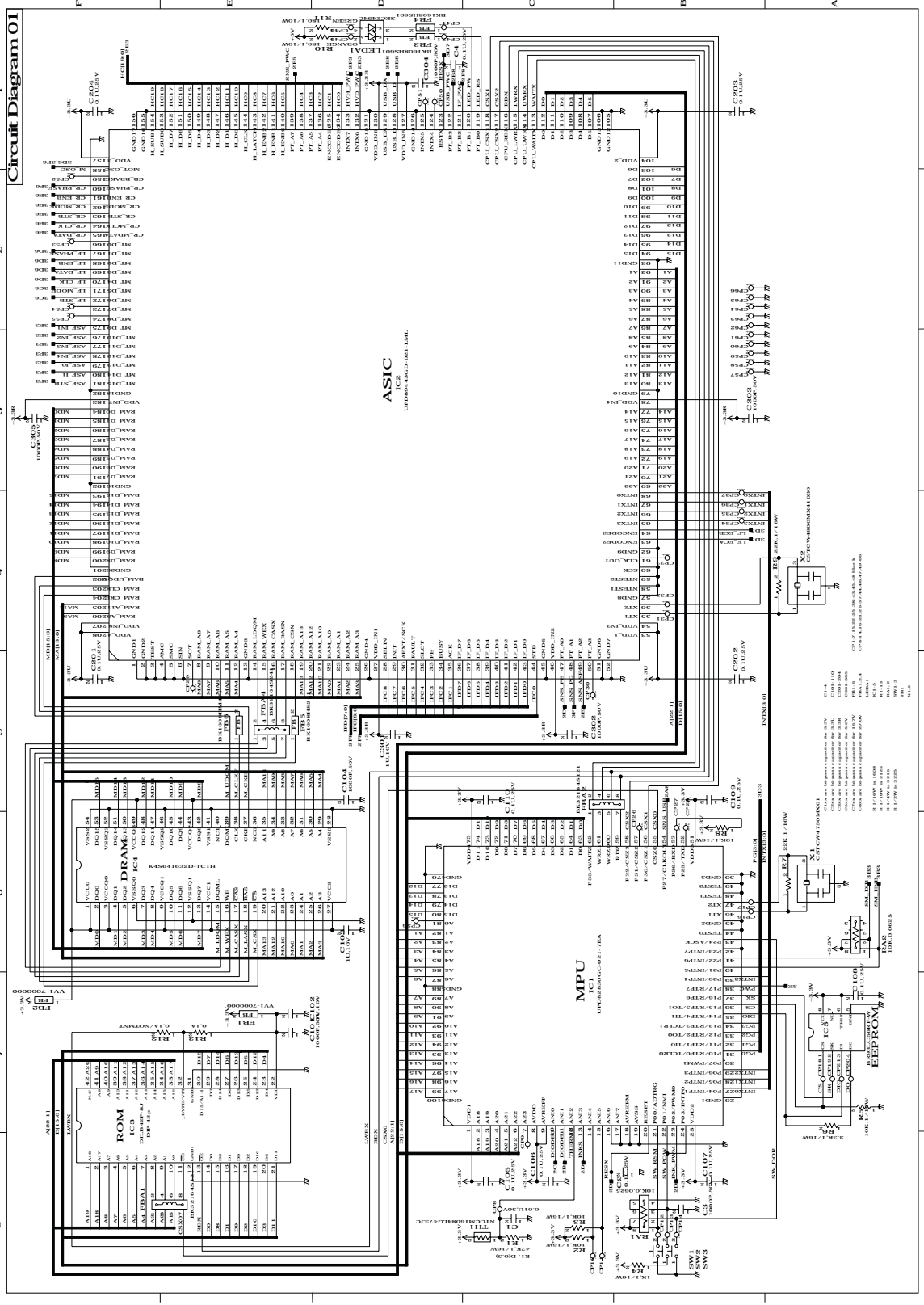
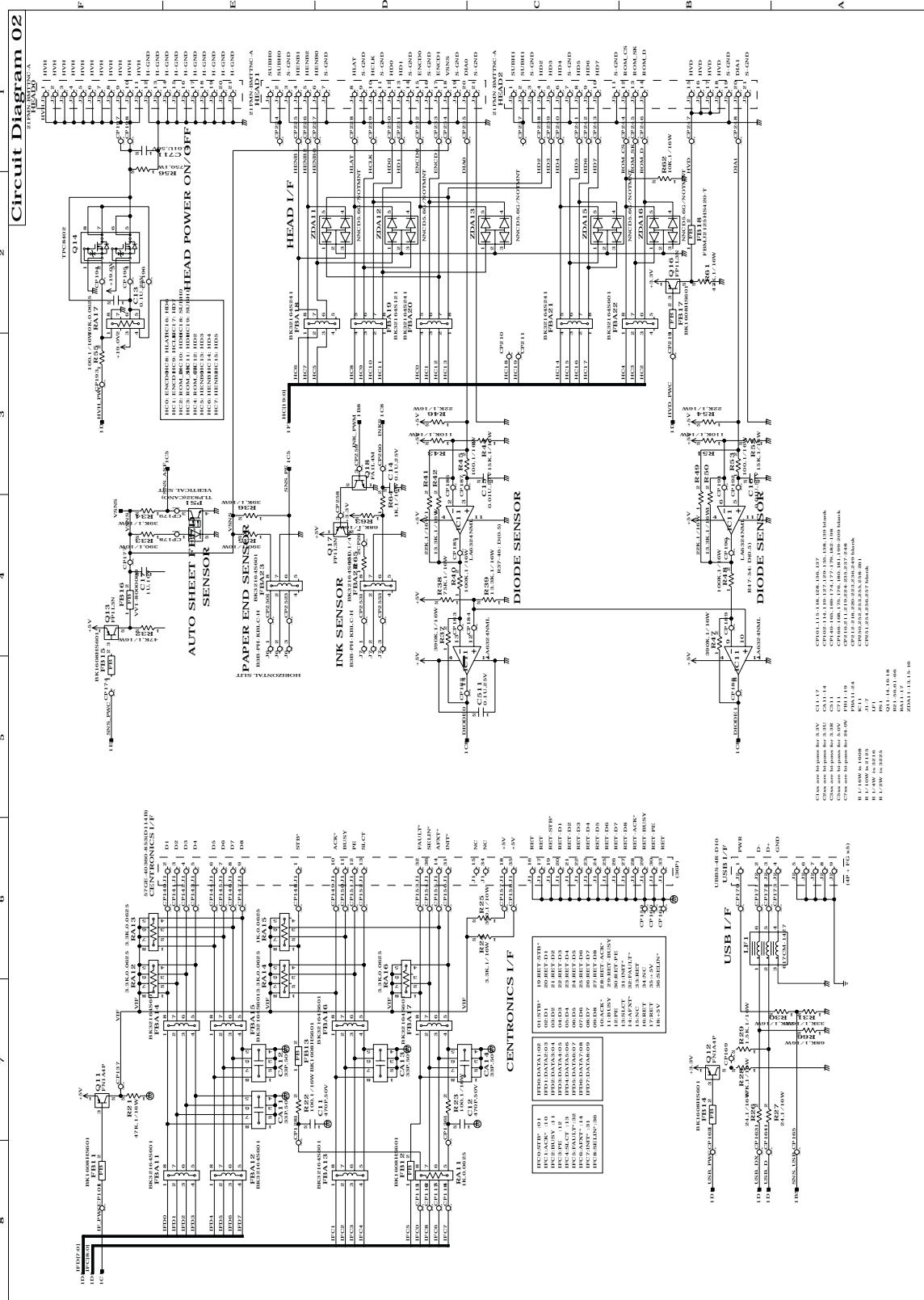

Figure 4-3 BJ Cartridge

Pin No.	Signal	IN/OUT	Function
1, 2	A_GND	...	GND (for black heater driving voltage)
3	H_D2	IN	Cyan even array nozzle data signal
4	H_D6	IN	Yellow even array nozzle data signal
5, 14, 22			
6, 7, 8	B_GND	...	GND (for color heater driving voltage)
9	DIK0	OUT	Head temperature sensor's (diode) cathode side (black)
10	SUBH0	IN	Black secondary heater driving voltage
11	H_D4	IN	Magenta even array nozzle data signal
12	H_ENB1	IN	Color nozzle heat enable signal (Even/odd array odd block)
13	N.C		
15	H_D5	IN	Magenta odd array nozzle data signal
16	DIK1	...	Head temperature sensor's (diode) cathode side (color)
17	H_D0	IN	Black even array nozzle data signal
18	H_ENB0	IN	Black nozzle heat enable signal
19	N.C		
20	H_LATCH	IN	Data latch enable signal
21	SUBH0	IN	Color secondary heater driving signal
23	H_D7	IN	Yellow odd array nozzle data signal
24	H_ENB2	IN	Color nozzle heat enable signal (Even/odd array's even block)
25	H_D1	IN	Black odd array nozzle data signal
26	DIA0	OUT	Black
27, 35	HVDD	IN	Logic power source
28	H_EEPROM_CS	IN	Head's EEPROM chip select signal
29	H_CLK	IN	Clock signal
30	E_D0	OUT	Head's EEPROM output data signal
31	H_D3	IN	Cyan odd array nozzle data signal
32, 40	B_VH	IN	Color heater driving voltage
33, 34	A_VH	IN	Black heater driving voltage
36	H_EEPROM_SK	IN	Head's EEPROM serial data clock signal
37	E_DI	IN	Head's EEPROM input data signal
38	DIA1	OUT	Head temperature sensor's (diode) anode side (color)
39	VHT	IN	Head's power transistor driving power source

2. CIRCUIT DIAGRAM





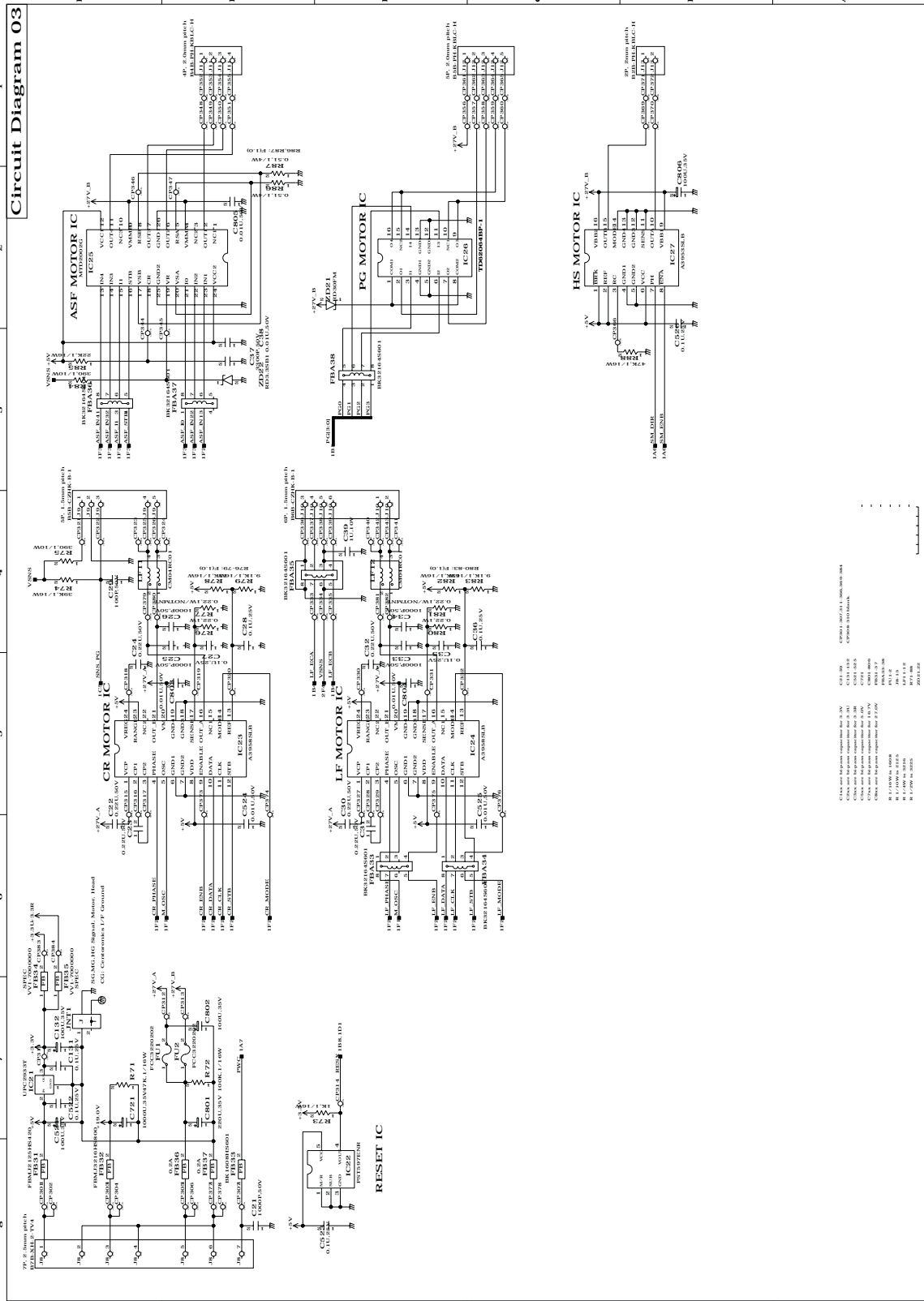



The printing paper contains
100% waste paper.

Canon